

Mechanical:

REV.	ECN NO.	DESCRIPTION	DATE	APPD
A	REL		2013/10/07	

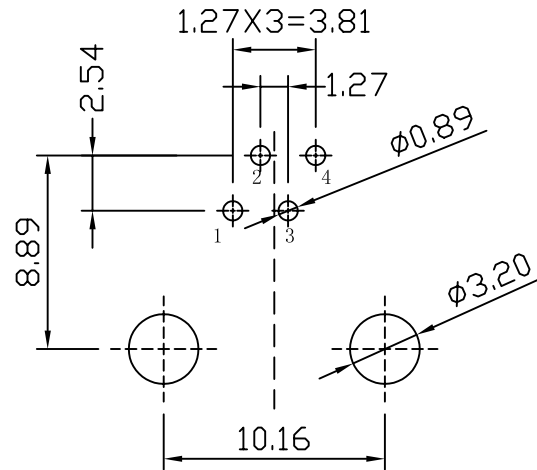
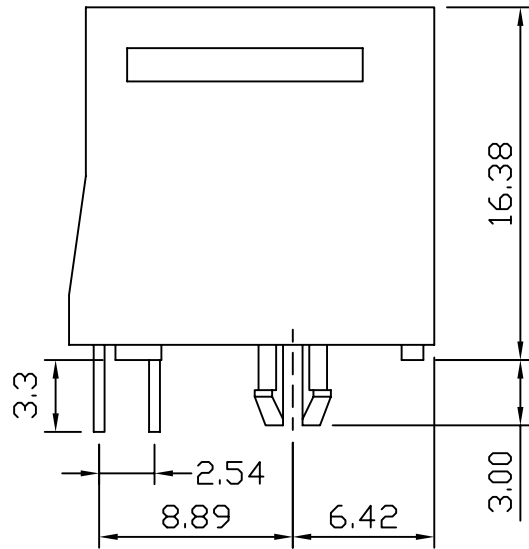
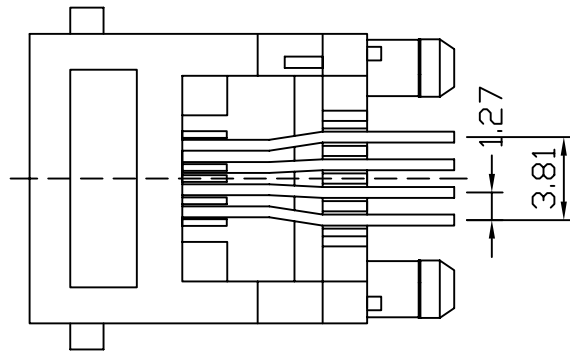
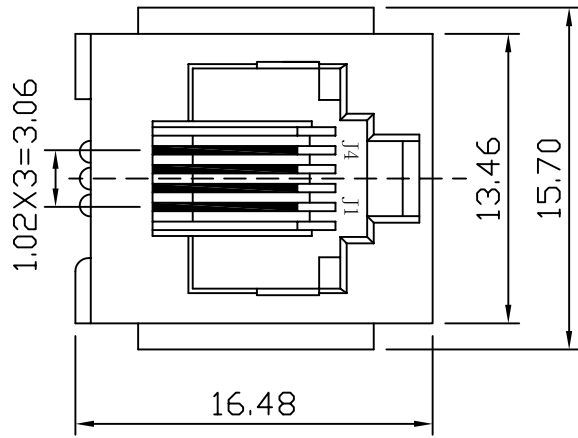

PC Board Layout (Top View)

MATERIAL:

- CONTACT WIRE: 0.46MM DIAMETER PHOSPHOR BRONZE
OPTIONAL GOLD PLATING OVER NICKEL
- DURABILITY: 1000 MATING CYCLES MINI

ELECTRICAL:

- CURRENT RATING : 1.5A
- VOLTAGE RATING : 125VACRMS
- CONTACT RESISTANCE : 20MΩ MAX
- INSULATION RESISTANCE : 100MΩ MIN
- WITHSTANDING VOLTAGE : 1000V AC FOR 1min.
- GOLD PLATING:
(GOLD FLASH; 1.5;3;6;15;30;50)U" INCH
- (1) STORAGE: -40°C to +85°C
(2) OPERATION: -40°C to +85°C
(3) WAVE SOLDER TEMPERATURE: 230°C to 250°C,
5~10 SEC.



X:X ±0.25	APPD:	LINK-PP INT'L TECHNOLOGY CO., LIMITED		
X:XX ±0.10	CHKD:	TITLE:		
X:XXX ±0.05	DR: TOM	VERTICAL PLASTIC 6P4C MODULAR JACK WITH EARS		
ANGLES ±1°	UNIT: mm	PART NO. : LPJE615NNL		
	SCALE: 2/1	SHEET: 1/1	REV: A	DWG NO. : LP13100701