

Mechanical:

REV.	ECN NO.	DESCRIPTION	DATE	APPD
A	REL		2016/03/03	

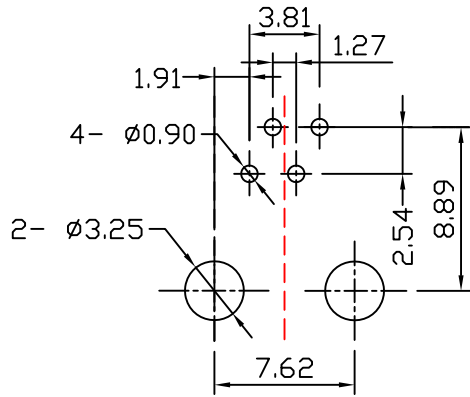

PC Board Layout (Top View)

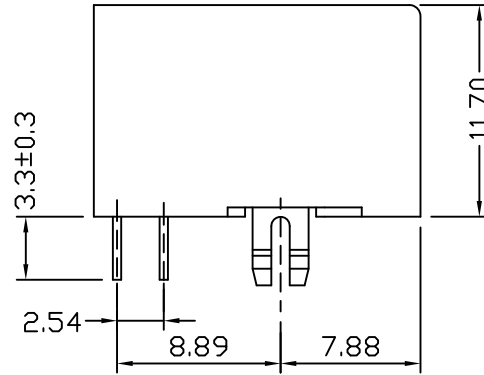
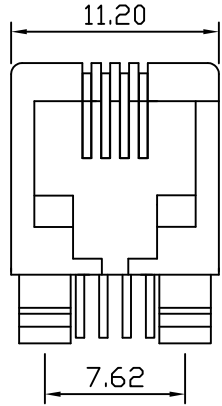
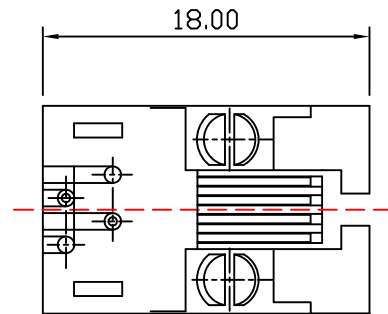

NOTES:

Electrical:

- 1. Voltage rating : 125 VAC RMS
- 2. Current Rating : 1.5 AMP
- 3. Contact resistance : 50 mΩ Max
- 4. Insulation resistance : 500 MΩ Min @500V DC
- 5. Dielectric strength : 1500 VAC RMS 60Hz, 1MIN.

MECHANICAL:

- 1. Housing & Insert Material : PBT UL94V-0.
- 2. Contact Material : Diameter 0.46mm Phosphor Bronze
Gold Plating Over Nickel.
- 3. Operating Life : 750 Cycles Min.

ENVIRONMENTAL:

- 1. Storage : -40°C ~ +85°C
- 2. Operation : -40°C ~ +85°C.
- 3. Wave solder temperature : 265°C MAX, 5 Sec.
- 4. UL Certification : File Number E484635.



X:X ±0.30	APPD:	LINK-PP INT'L TECHNOLOGY CO., LIMITED		
X:XX ±0.25	CHKD:	TITLE: RJ11 1×1 CONNECTOR 4P4C		
X:XXX ±0.05	DR: TOM	PART NO.: LPJE0003NNL		
ANGLES ±1°	UNIT: mm	DWG NO.: LP16030310		
	SCALE: 2/1	SHEET: 1/1	REV: A	DWG NO.: LP16030310