

Schematic:

REV.	ECN NO.	DESCRIPTION	DATE	APPD
A	REL		2013/03/21	

PC BOARD CONNECTIONS

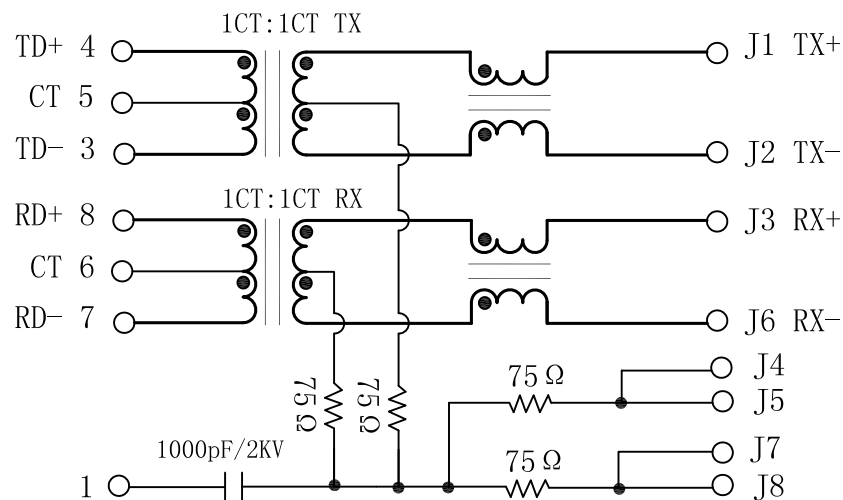

RJ45 CONNECTOR

Electrical Specifications @25°C

1. OCL (100KHz, 0.1V, 8mA DC BIAS):
350uH MIN
2. Insertion Loss:
0.5~100MHz: -1.1dB MAX
3. Return Loss:
0.5~30MHz: -18dB MIN
30.1~60MHz: $-[18-20\text{LOG}(f/30)]$ dB MIN.
60.1~80MHz: -12dB MIN
4. Crosstalk:
0.5~40MHz: -35dB MIN
40.1~100MHz: $-[33-20\text{LOG}(f/50)]$ dB MIN.
5. Common Mode Rejection Ratio:
0.5~100MHz: -30dB MIN
6. Hipot Test: 1500Vrms MIN
7. Operating Temperature: 0°C TO +70°C.

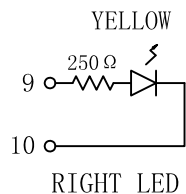
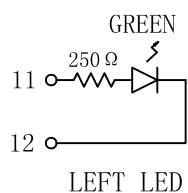

X:X	±0.30	APPD:	LINK-PP INT'L TECHNOLOGY CO., LIMITED
X:XX	±0.25	CHKD:	
X:XXX	±0.05	DR: TOM	TITLE: RJ45 Connector With 10/100 Base-TX Integrated Magnetic TAB UP
ANGLES	±1°	UNIT: mm	PART NO.: LPJ28193A28NL
	SCALE: 2/1	SHEET: 1/2	REV: A DWG: LP13032102

Mechanical:

REV.	ECN NO.	DESCRIPTION	DATE	APPD
A	REL		2013/03/21	

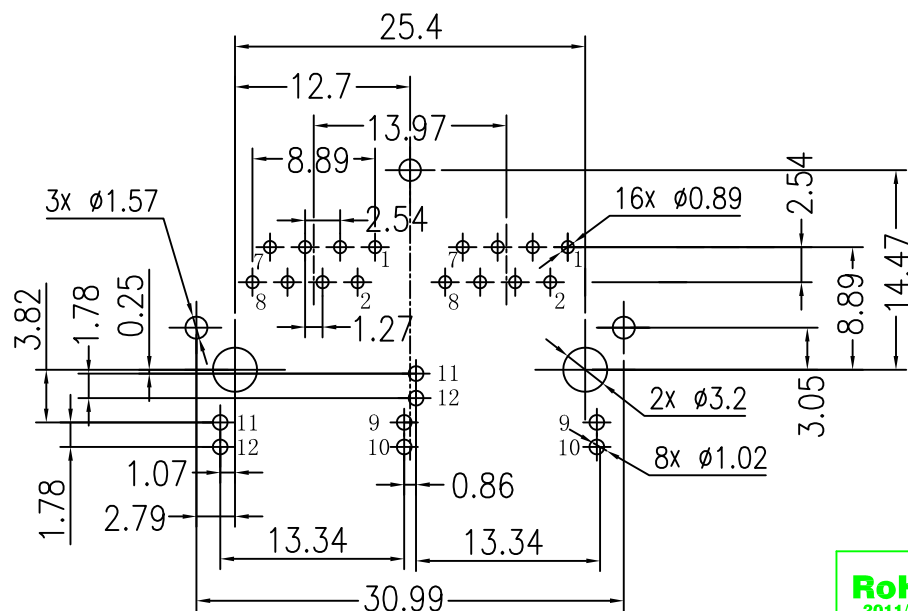
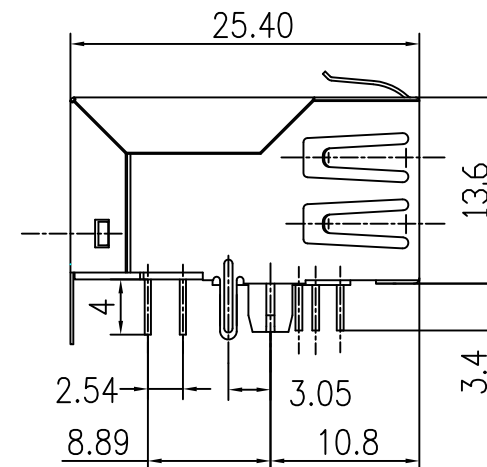
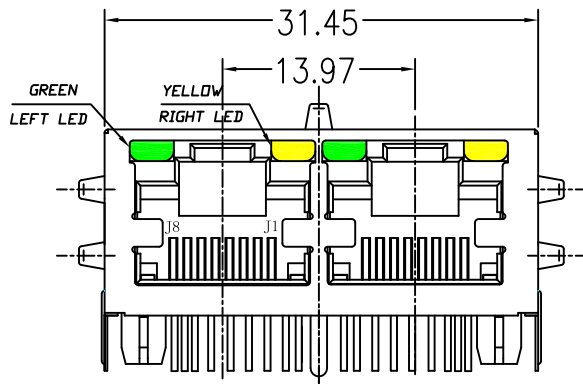

SUGGESTED PCB LAYOUT (TOP VIEW)



NOTES:

1. Designed to support application, such as SOHO (ADSL modems), LAN-on-Motherboard (LOM), hub and Switches.
2. Meets IEEE 802.3 specification
3. Connector Materials:
 Housing: Thermoplastic UL94V-0
 Contact/Shield: Copper alloy
 Shield plating: Nickel
 Contact plating: Gold 6 micro-inches min. In contact area.
4. Wave solder tip temperature: 265°C Max, 5 Sec Max.

X:X	±0.30	APPD:	LINK-PP INT'L TECHNOLOGY CO., LIMITED	
X:XX	±0.25	CHKD:	TITLE: RJ45 Connector With 10/100 Base-TX Integrated Magnetic TAB UP	
X:XXX	±0.05	DR: TOM		
ANGLES	±1°	UNIT: mm	PART NO.: LPJ28193A28NL	
	SCALE: 2/1	SHEET: 2/2	REV: A	DWG: LP13032102