

Schematic:

REV.	ECN NO.	DESCRIPTION	DATE	APPD
A	REL		10/08/2009	

PCB SIDE TO PHY

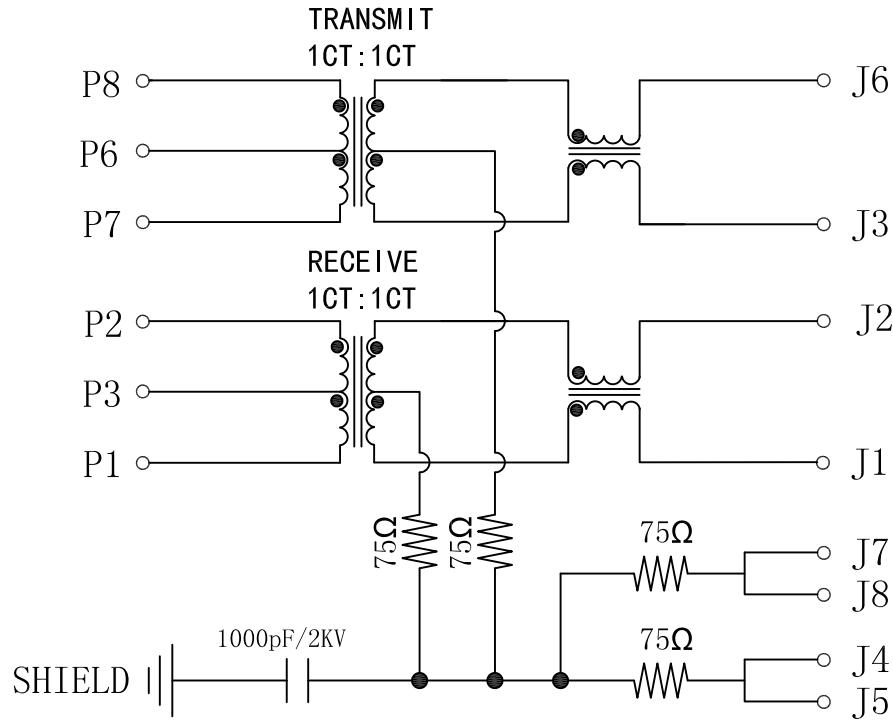

CABLE SIDE

Electrical Specification @25°C

- Turns Ratio ($\pm 2\%$):
TX=1CT : 1CT RX=1CT : 1CT
- OCL: 350uH Min
@100KHz 100mVrms 8mA DC bias current
- Insertion Loss(dB Max):
1-80MHz:-1.0 100MHz:-1.2
- Return Loss(dB Min @100Ω):
1-60MHz:-14 60-100MHz:-10
- Crosstalk: 1-80MHz:-35dB Min
- IR Reflow peak temperature: 260 degc.
- Isolation Voltage: 1500Vrms Min
- Operating Temperature: -40°C ~ +85°C.

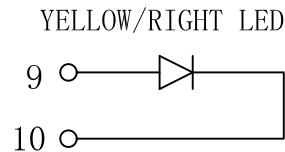
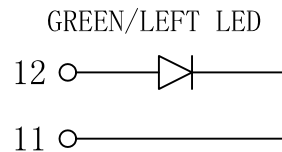

X:X	±0.30	APPD:	LINK-PP INT'L TECHNOLOGY CO., LIMITED	
X:XX	±0.25	CHKD:	TITLE: Surface Mount IX1 Tab-Up Jack With 10/100 Magnetic	
X:XXX	±0.05	DR: TOM	PART NO.: LPJ19401BBNL	
ANGLES	±1°	UNIT: mm		
	SCALE: 2/1	SHEET: 1/2	REV: A	DWG NO.: LP09081009

Mechanical:

REV.	ECN NO.	DESCRIPTION	DATE	APPD
A	REL		10/08/2009	

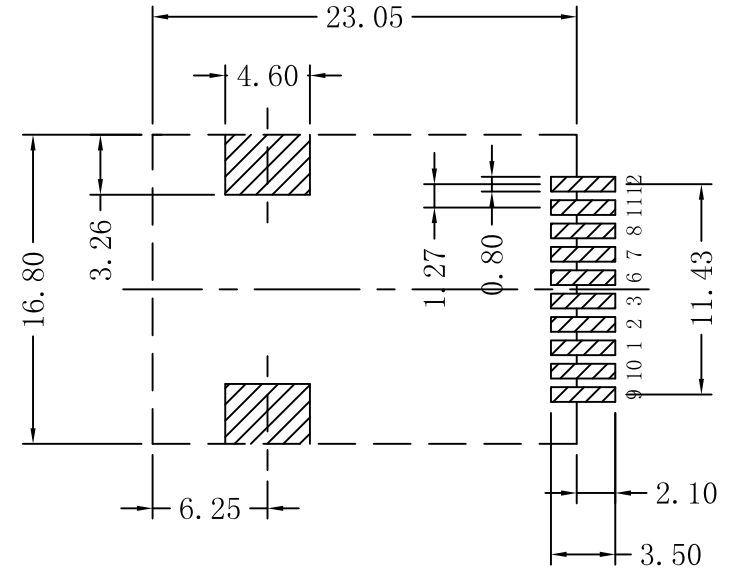
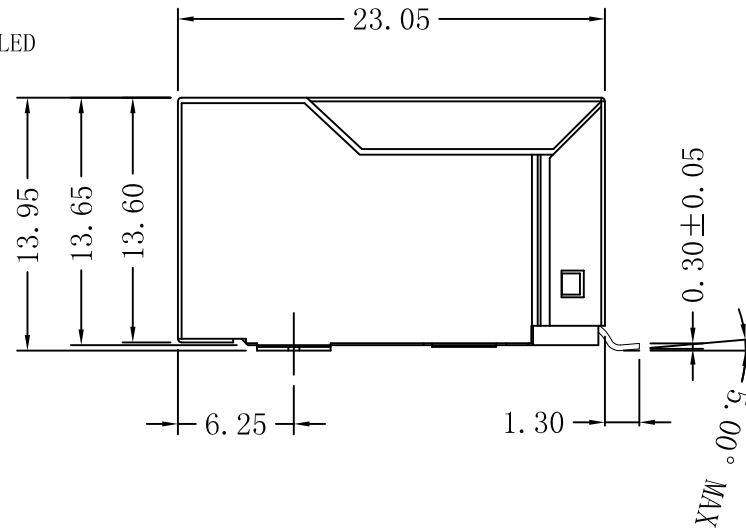
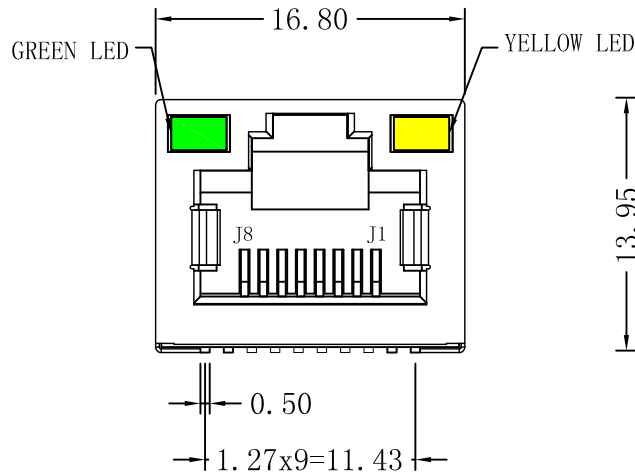

SUGGESTED PCB LAYOUT (TOP VIEW)

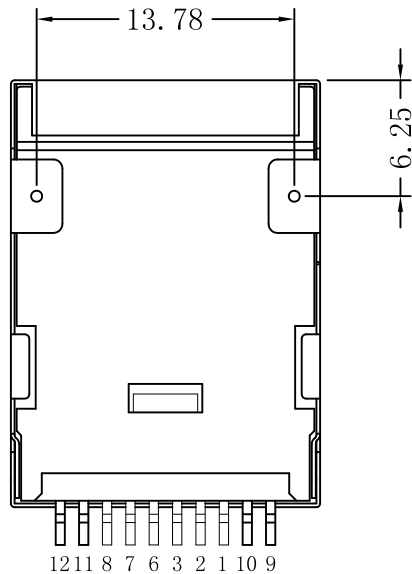

NOTES:

1. Designed to support application, such as SOHO (ADSL modems), LAN-on-Motherboard (LOM), hub and Switches.
2. Meets IEEE 802.3 specification
3. Connector Materials:
 Housing: Thermoplastic LCP+30%G.F UL94V-0
 Contact/Shield: Copper alloy
 Shield plating: Nickel
 Contact plating: Gold 6 micro-inches min. In contact area.
4. Wave solder tip temperature: 265°C Max
 Wave solder tip temperature time: 5 Sec Max



X:X	±0.30	APPD:	LINK-PP INT'L TECHNOLOGY CO., LIMITED
X:XX	±0.25	CHKD:	
X:XXX	±0.05	DR: TOM	TITLE: Surface Mount IX1 Tab-Up Jack With 10/100 Magnetic
ANGLES	±1°	UNIT: mm	PART NO.: LPJ19401BBNL
	SCALE: 2/1	SHEET: 2/2	REV: A DWG NO.: LP09081009