

Schematic:

REV.	ECN NO.	DESCRIPTION	DATE	APPD
A	REL		18/06/2009	

PCB SIDE TO PHY

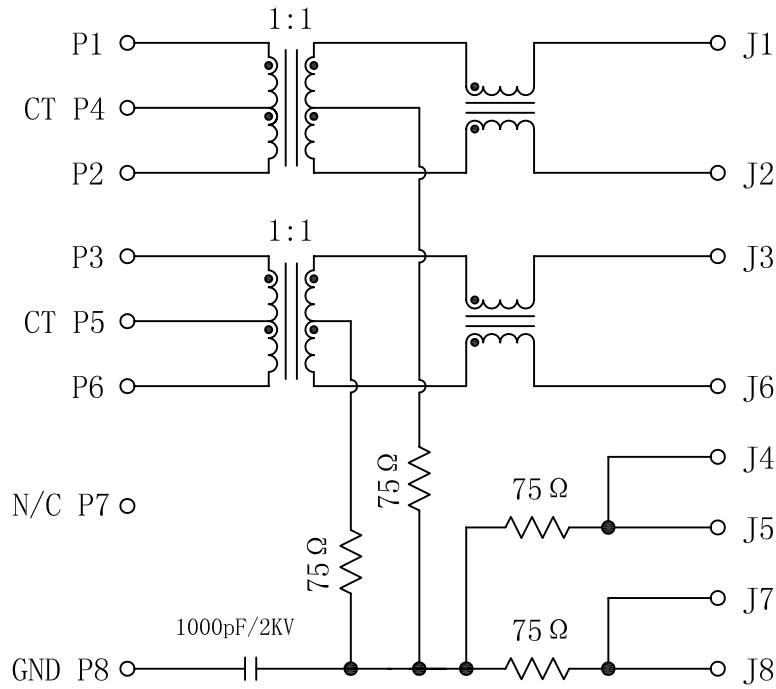

CABLE SIDE

ELECTRICAL SPECIFICATIONS @25°C

- Turn Ratio ($\pm 3\%$):
 (P1-P2) : (J1-J2) = 1CT:1
 (P3-P6) : (J3-J6) = 1CT:1
- OCL (100KHz, 0.1Vrms, 8mA):
 (P1-P2, P3-P6) : 350uH MIN
- Insertion Loss:
 -1.1dB MAX @ 0.1-100MHz
- Return Loss:
 -18dB MIN @ 0.5-30MHz
 -15.5dB MIN @ 40MHz
 -13.6dB MIN @ 50MHz
 -12dB MIN @ 60-80MHz
- Cross talk:
 -40dB TYP @ 1-100MHz
- Common Mode Rejection:
 -50dB TYP @ 0.1-30MHz
 -40dB TYP @ 30-60MHz
 -35dB TYP @ 60-100MHz
- Isolation: 1500Vrms
- Operating Temperature: 0°C TO 70°C.

YELLOW/LEFT LED

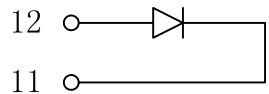

GREEN/RIGHT LED

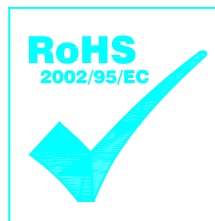
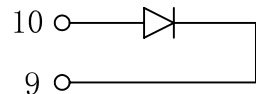

X:X	± 0.25	APPD:	LINK-PP INT'L TECHNOLOGY CO., LIMITED	
X:XX	± 0.20	CHKD:	TITLE: RJ45 Connector with 10/100 Base-TX Integrated Magnetics	
X:XXX	± 0.05	DR: TOM		
ANGLES	$\pm 1^\circ$	UNIT: mm	PART NO. : LPJ1004AGNL	
	SCALE: 2/1	SHEET: 1/2	REV: A	DWG NO. : TRC10062302

Mechanical:

REV.	ECN NO.	DESCRIPTION	DATE	APPD
A	REL		18/06/2009	

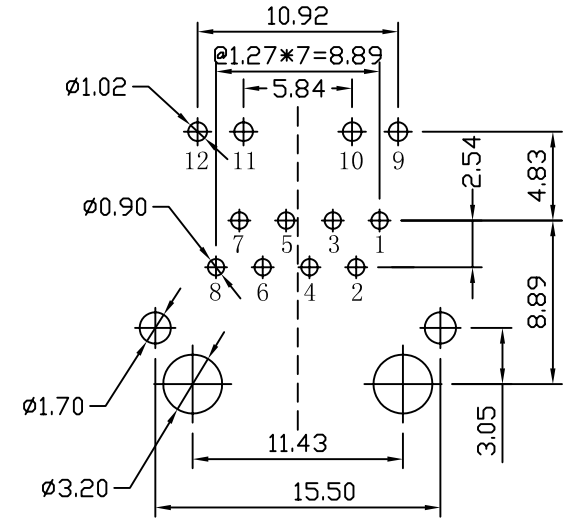
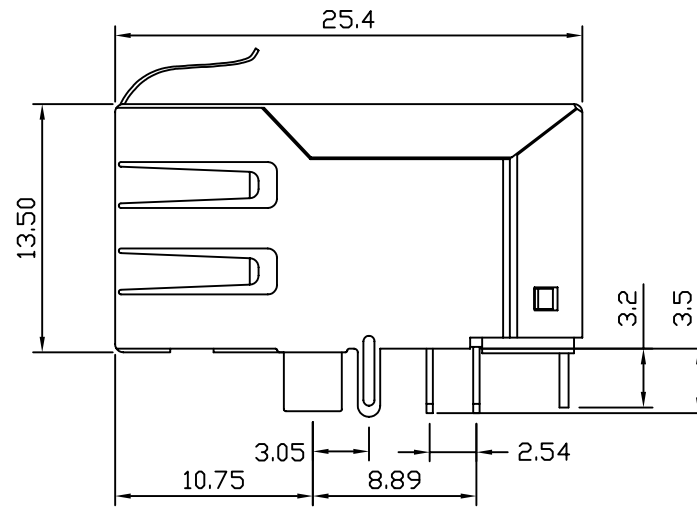
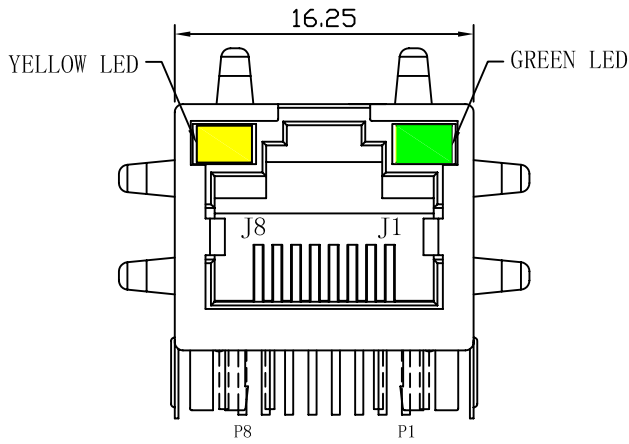

SUGGESTED PCB LAYOUT (TOP VIEW)

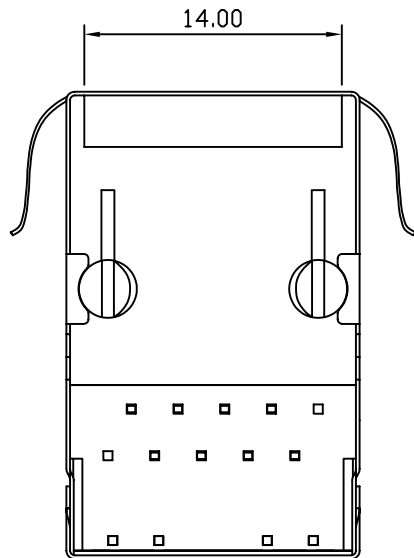

NOTES:

1. Designed to support application, such as SOHO (ADSL modems), LAN-on-Motherboard (LOM), hub and Switches.
2. Meets IEEE 802.3 specification
3. Connector Materials:
 Housing: Thermoplastic UL94V-0
 Contact/Shield: Copper alloy
 Shield plating: Nickel
 Contact plating: Gold 6 micro-inches min. In contact area.
4. Wave solder tip temperature: 265°C Max
 Wave solder tip temperature time: 5 Sec Max

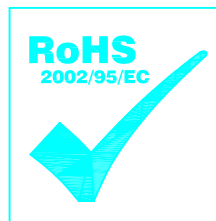

X:X ±0.25	APPD:	LINK-PP INT'L TECHNOLOGY CO., LIMITED
X:XX ±0.20	CHKD:	
X:XXX ±0.05	DR: TOM	TITLE: RJ45 Connector with 10/100 Base-TX Integrated Magnetics
ANGLES ±1°	UNIT: mm	PART NO.: LPJ1004AGNL
	SCALE: 2/1	SHEET: 2/2
	REV: A	DWG NO.: TRC10062302