

Mechanical:

REV.	ECN NO.	DESCRIPTION	DATE	APPD
A	REL		2010/09/27	

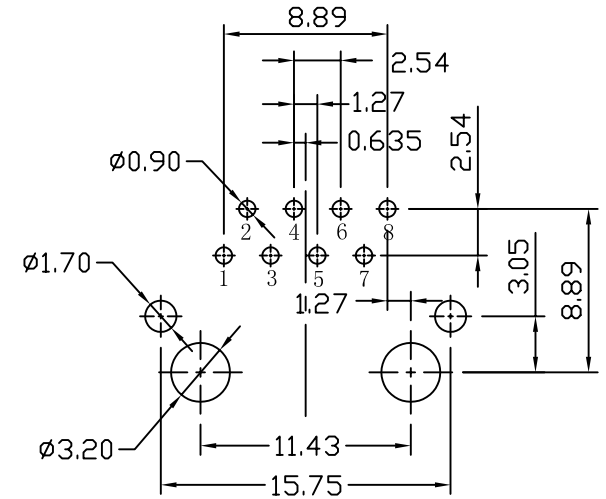

SUGGESTED PCB LAYOUT (TOP VIEW)

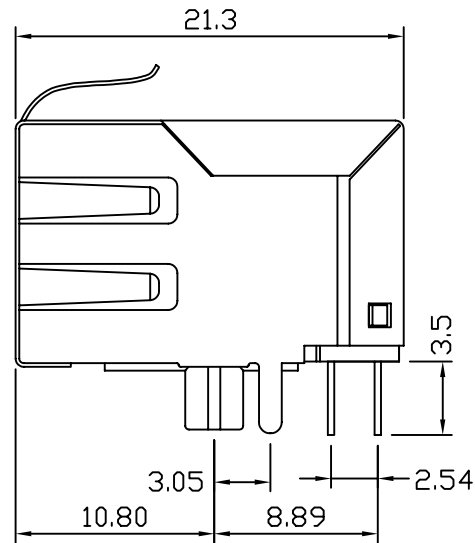
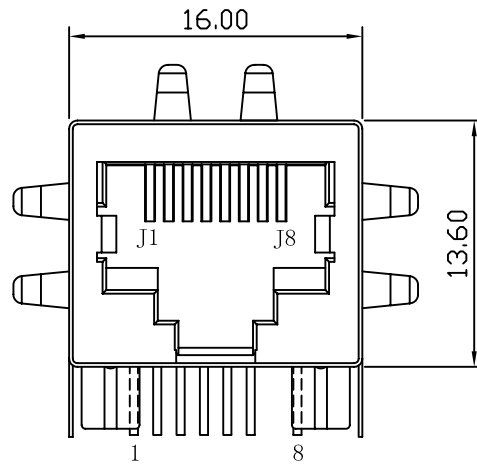
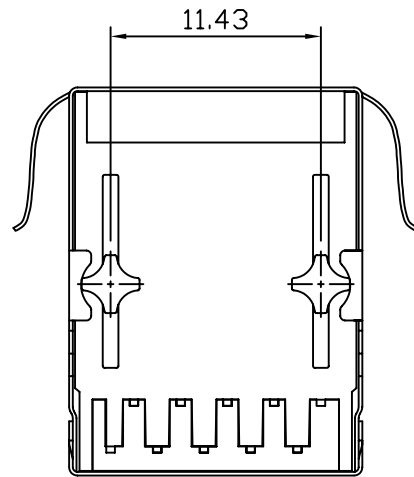

NOTES:

1. Designed to support application, such as SOHO (ADSL modems), LAN-on-Motherboard (LOM), hub and Switches.
2. Meets IEEE 802.3 specification
3. Connector Materials:
 Housing: Thermoplastic UL94V-0
 Contact/Shield: Copper alloy
 Shield plating: Nickel
 Contact plating: Gold 6 micro-inches min. In contact area.
4. Wave solder tip temperature: 265°C Max
 Wave solder tip temperature time: 5 Sec Max



X:X	±0.30	APPD:	LINK-PP INT'L TECHNOLOGY CO., LIMITED	
X:XX	±0.20	CHKD:	TITLE: RJ45 Connector With 10 Base-TX Integrated Magnetics	
X:XXX	±0.05	DR: TOM	PART NO.: LPJ0520CNL	
ANGLES	±1°	UNIT: mm		
	SCALE: 2/1	SHEET: 1/2	REV: A	DWG NO.: LP10092706

Schematic:

REV.	ECN NO.	DESCRIPTION	DATE	APPD
A	REL		2010/09/27	

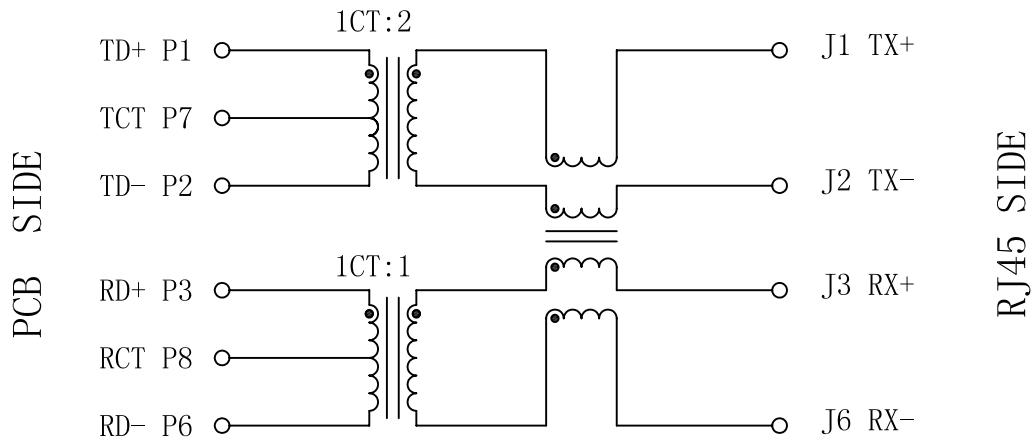

Electrical Specifications @25°C

- Turns Ratio:
 - (P6-P8-P3) : (J6-J3) : 1CT:1 ±3%
 - (P2-P7-P1) : (J2-J1) : 1CT:2 ±3%
- Inductance:
 - (P6-P3)=(J6-J3) : 98uH MIN @0.01V, 10KHz
 - (P2-P1) : 18uH MIN @0.01V, 10KHz
- Leakage Inductance:
 - P6-P3(With J6 and J3 short): 0.3uH MAX @1MHz
 - P2-P1(With J2 and J1 short): 0.08uH MAX @1MHz
- Interwinding Capacitance:
 - (P6, P3) to (J6, J3) : 8pF MAX @ 1MHz
 - (P2, P1) to (J2, J1) : 6pF MAX @ 1MHz
- DC Resistance:
 - (J6-J3)=(J2-J1) : 0.7 ohms MAX
 - (P6-P8)=(P8-P3) : 0.3 ohms MAX
 - (P2-P7)=(P7-P1) : 0.3 ohms MAX
- Dielectric Withstand:
 - (P6, P3) to (J6, J3) : 1500Vrms
 - (P2, P1) to (J2, J1) : 1500Vrms
- Operating Temperature: 0°C ~ 70°C



X:X	±0.30	APPD:	LINK-PP INT'L TECHNOLOGY CO., LIMITED	
X:XX	±0.20	CHKD:	TITLE: RJ45 Connector With 10 Base-TX Integrated Magnetics	
X:XXX	±0.05	DR: TOM	PART NO. : LPJ0520CNL	
ANGLES	±1°	UNIT: mm	DWG NO. : LP10092706	
	SCALE: 2/1	SHEET: 2/2	REV: A	