

Schematic:

REV.	ECN NO.	DESCRIPTION	DATE	APPD
A	REL		25/12/2007	

PC BOARD CONNECTIONS

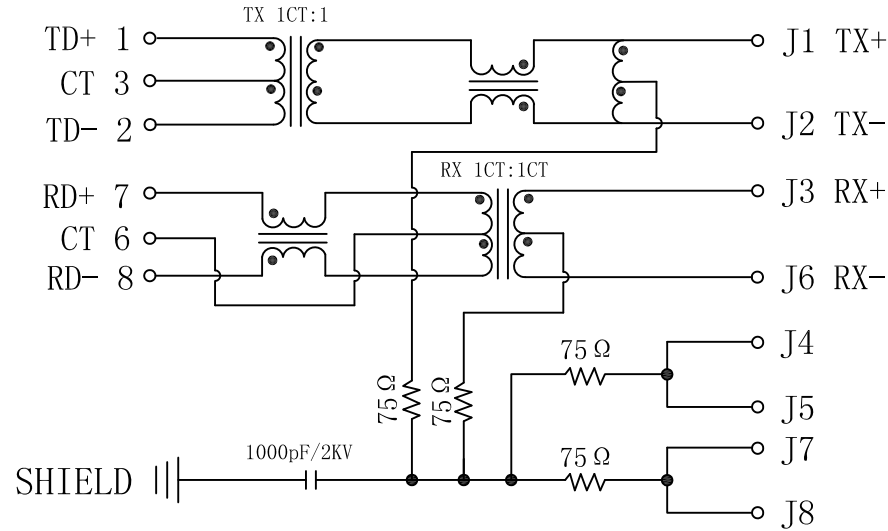

RJ45 CONNECTOR

ELECTRICAL SPECIFICATIONS @25°C

- Turn Ratio ($\pm 2\%$):
TX=1CT:1 RX=1CT:1CT
- Inductance OCL: 350uH MIN
@100KHz/0.1V, 8mA DC Bias
- Insertion Loss:
-1.0dB MAX @ 1.0-100MHz
- Return Loss:
-18dB MIN @ 1-30MHz
-16dB MIN @ 30-60MHz
-12dB MIN @ 60-80MHz
- Cross talk:
-35dB MIN @ 1-100MHz
- Common Mode Rejection:
-30dB MIN @ 1-100MHz
- Hipot Test: 1500Vrms MIN
- Operating Temperature Range: 0°C TO 70°C

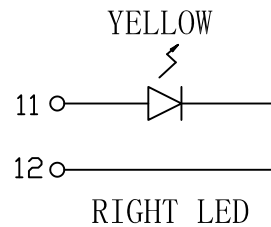
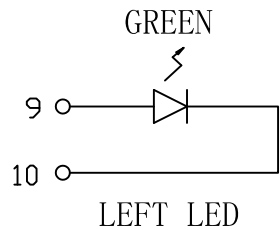

X:X	± 0.25	APPD:	LINK-PP INT'L TECHNOLOGY CO., LIMITED	
X:XX	± 0.20	CHKD:	TITLE: RJ45 Connector 10/100 Base-TX With Integrated Magnetics	
X:XXX	± 0.05	DR: TOM	PART NO.: LPJ0025AENL	
ANGLES	$\pm 1^\circ$	UNIT: mm	DWG NO.: LP07122511	
	SCALE: 2/1	SHEET: 1/2	REV: A	

Mechanical:

REV.	ECN NO.	DESCRIPTION	DATE	APPD
A	REL		25/12/2007	

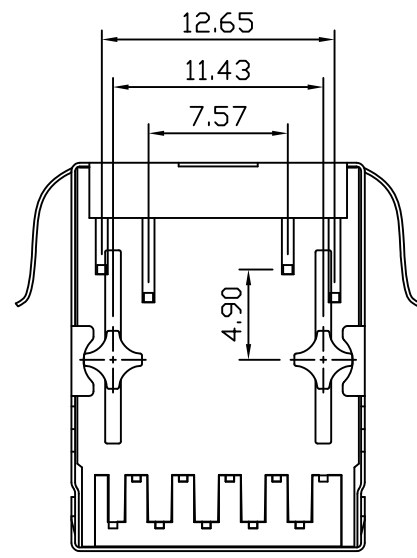
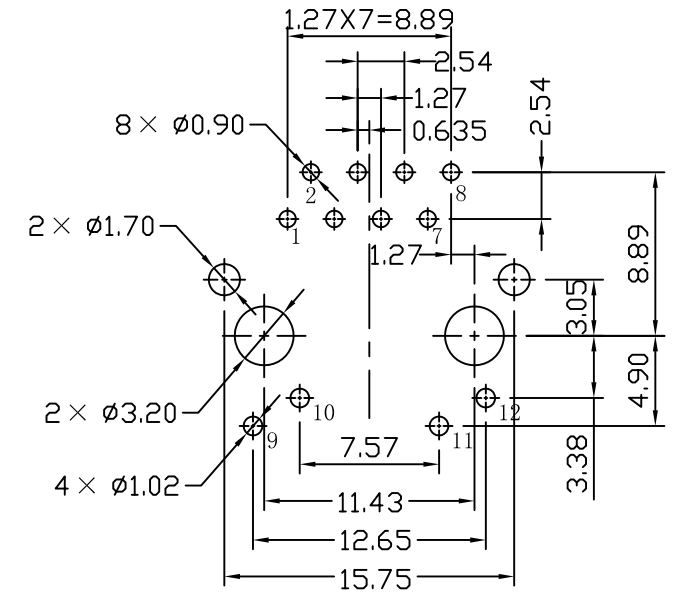
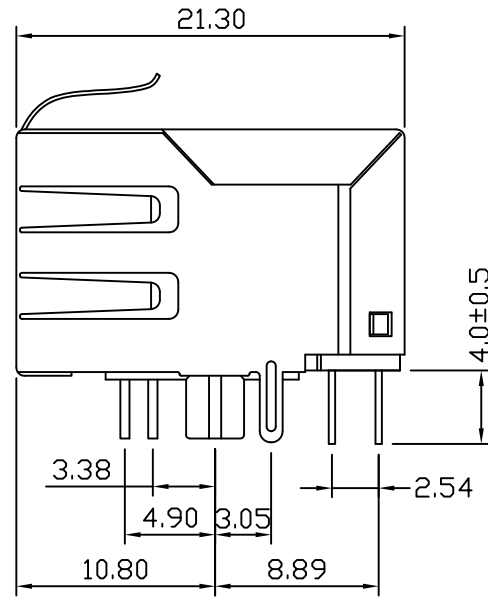
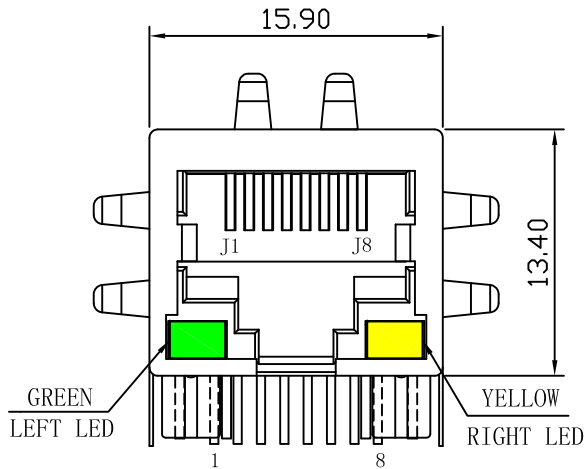

NOTES:

1. Designed to support application, such as SOHO (ADSL modems), LAN-on-Motherboard (LOM), hub and Switches.
2. Meets IEEE 802.3 specification
3. Connector Materials:
 Housing: Thermoplastic UL94V-0
 Contact/Shield: Copper alloy
 Shield plating: Nickel
 Contact plating: Gold 6 micro-inches min. In contact area.
4. Wave solder tip temperature: 265°C Max
 Wave solder tip temperature time: 5 Sec Max



X:X ±0.25	APPD:	LINK-PP INT'L TECHNOLOGY CO., LIMITED
X:XX ±0.20	CHKD:	
X:XXX ±0.05	DR: TOM	TITLE: RJ45 Connector 10/100 Base-TX With Integrated Magnetics
ANGLES ±1°	UNIT: mm	PART NO.: LPJ0025AENL
	SCALE: 2/1	SHEET: 2/2
	REV: A	DWG NO.: LP07122511