

Schematic:

REV.	ECN NO.	DESCRIPTION	DATE	APPD
A	REL		30/11/2007	

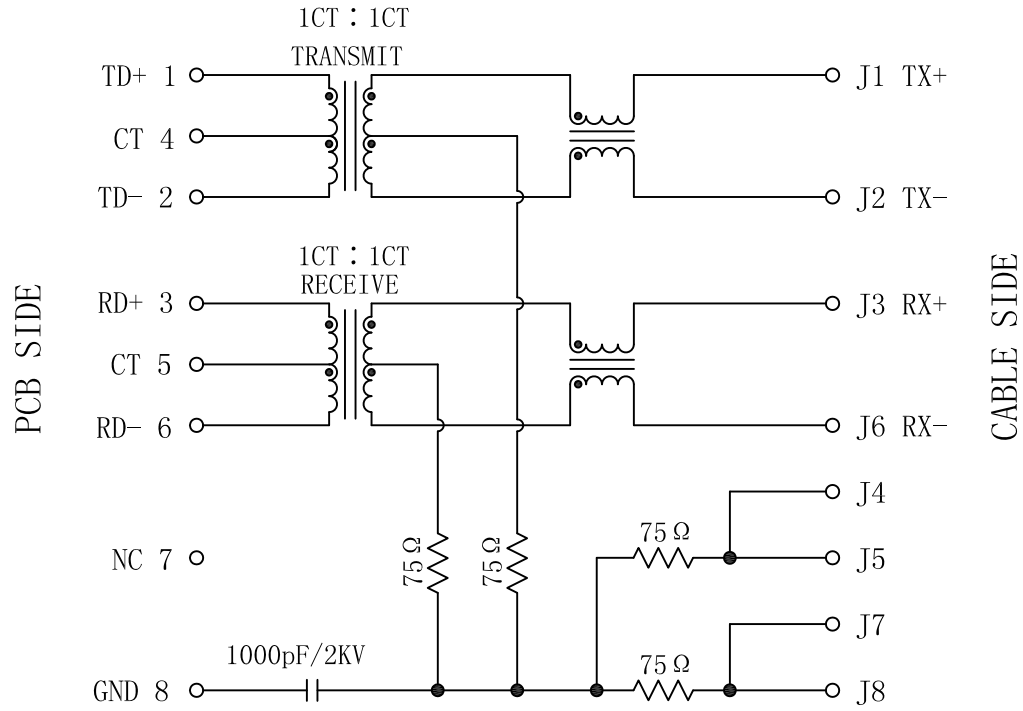

ELECTRICAL SPECIFICATIONS @25°C

- Turn Ratio(±2%) :
TX=1CT : 1CT RX=1CT : 1CT
- Inductance OCL: 350uH MIN
@100KHz/0.1V, 8mA DC Bias
- Insertion Loss:
-1.0dB MAX @ 1.0~65MHz
- Return Loss:
-20dB MIN @ 1~10MHz
-16dB MIN @ 10~30MHz
-12dB MIN @ 30~60MHz
-10dB MIN @ 60~100MHz
- Cross talk:
-40dB MIN @ 1~30MHz
-35dB MIN @ 30~60MHz
-30dB MIN @ 60~100MHz
- Common Mode Rejection:
-30dB MIN @ 1~50MHz
-20dB MIN @ 50~150MHz
- Hipot Test:1500Vrms MIN
- Operating Temperature Range: 0°C~70°C.

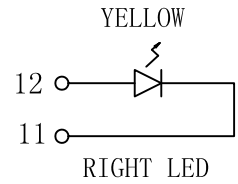
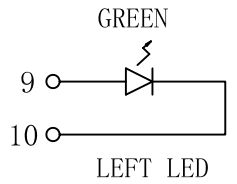

X:X ±0.30	APPD:	LINK-PP INT'L TECHNOLOGY CO., LIMITED
X:XX ±0.25	CHKD:	
X:XXX ±0.05	DR: TOM	TITLE: RJ45 Connector with 10/100 Base-T Integrated Magnetics
ANGLES ±1°	UNIT: mm	PART NO.: LPJ0011HBNL
	SCALE: 2/1	SHEET: 1/2
	REV: A	DWG NO.: LP07113012

Mechanical:

REV.	ECN NO.	DESCRIPTION	DATE	APPD
A	REL		30/11/2007	

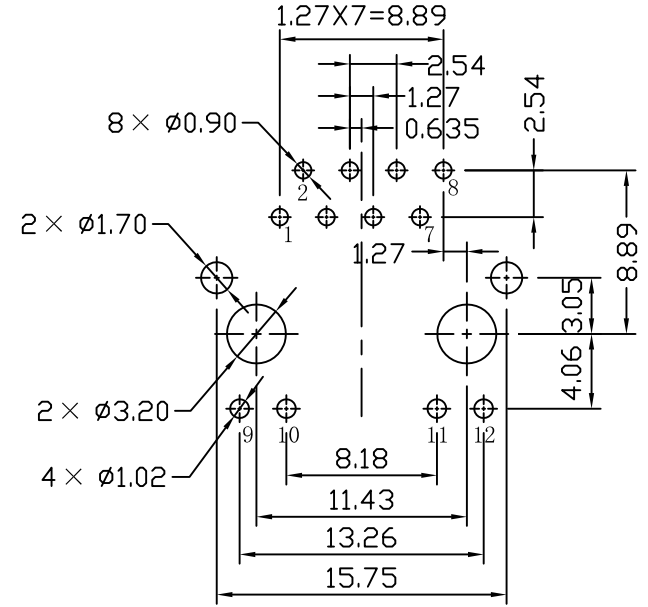
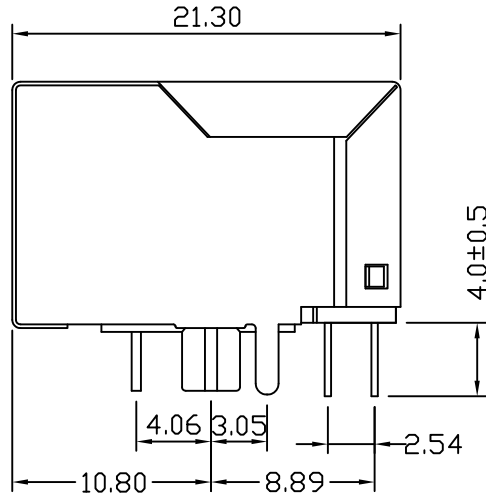
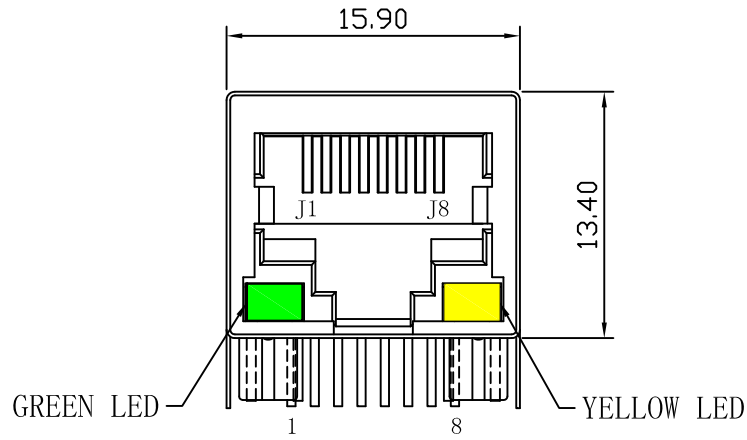

SUGGESTED PCB LAYOUT (TOP VIEW)

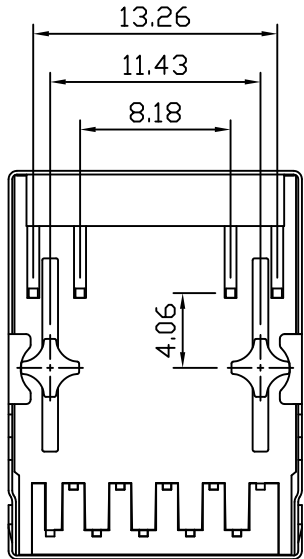

NOTES:

1. Designed to support application, such as SOHO (ADSL modems), LAN-on-Motherboard (LOM), hub and Switches.
2. Meets IEEE 802.3 specification
3. Connector Materials:
 Housing: Thermoplastic UL94V-0
 Contact/Shield: Copper alloy
 Shield plating: Nickel
 Contact plating: Gold 6 micro-inches min. In contact area.
4. Wave solder tip temperature: 265°C Max
 Wave solder tip temperature time: 5 Sec Max



X:X ±0.30	APPD:	LINK-PP INT'L TECHNOLOGY CO., LIMITED
X:XX ±0.25	CHKD:	
X:XXX ±0.05	DR: TOM	TITLE: RJ45 Connector with 10/100 Base-T Integrated Magnetics
ANGLES ±1°	UNIT: mm	PART NO.: LPJ0011HBNL
	SCALE: 2/1	SHEET: 2/2
	REV: A	DWG NO.: LP07113012