

Mechanical:

REV.	ECN NO.	DESCRIPTION	DATE	APPD
A	REL		2011/08/02	

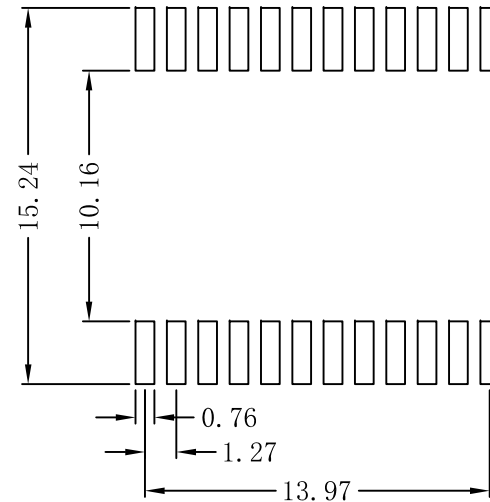

SUGGESTED PAD LAYOUT

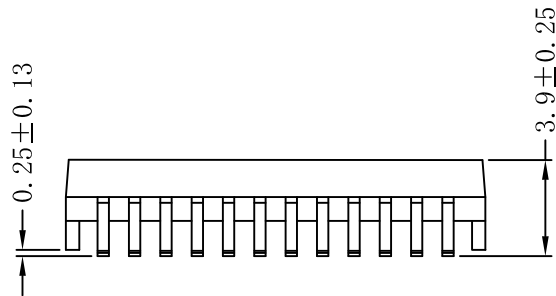
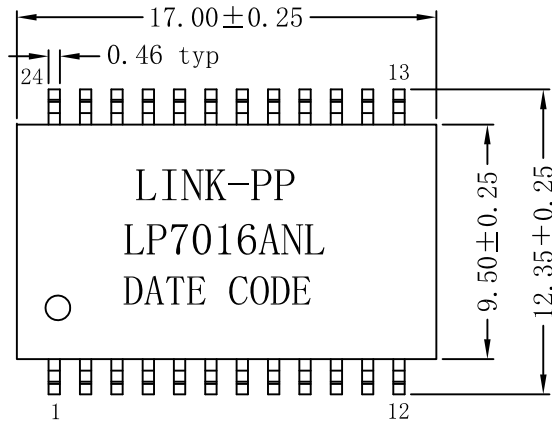
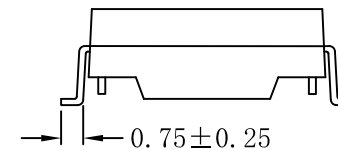

NOTES:

1. 10000Base-T PC Card SMD Transformer Module
2. Designed to meet IEEE802.3ae requirement
3. Lead-Free & Designed to meet RoHS requirement.
4. Maximum reflow temperature is  $250^{\circ}\text{C}$ , 5 Sec.
5. UL certification: file number E484635.

Dimensions: mm

Unless otherwise specified, all tolerances are  $\pm 0.25$

X:X	APPD:	<b>LINK-PP</b>		
X:XX $\pm 0.25$	CHKD:	LINK-PP INT'L TECHNOLOGY CO., LIMITED		
X:XXX	DR: TOM	TITLE: 10G Base-T PC Card SMD Transformer Module		
ANGLES $\pm 1^{\circ}$	UNIT: mm	PART NO.: LP7016ANL		
	SCALE: 2/1	SHEET: 1/2	REV: A	DWG NO.: LP11080669

# Schematic:

REV.	ECN NO.	DESCRIPTION	DATE	APPD
A	REL		2011/08/02	

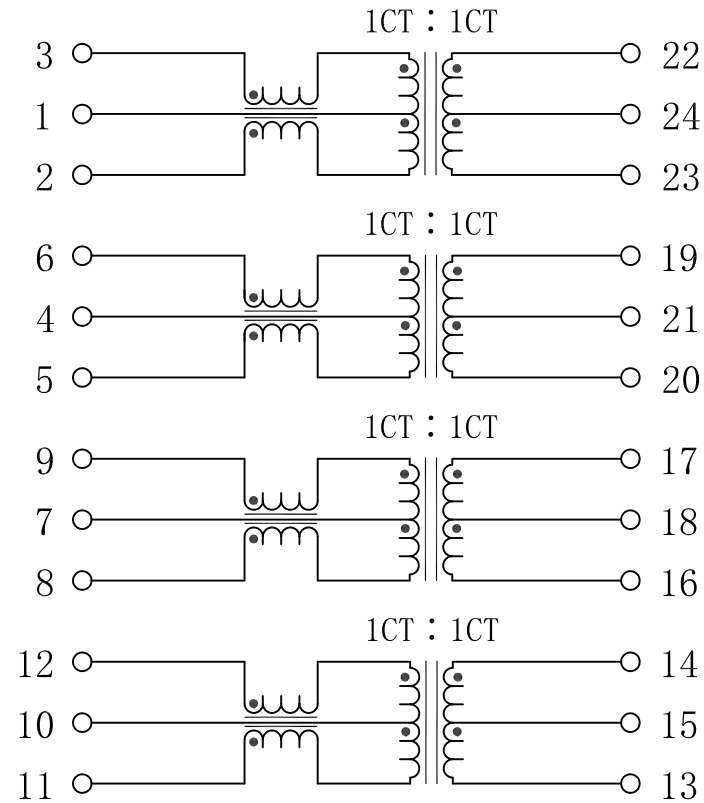

## Electrical Specifications @25°C

1. Turn Ratio: 1CT : 1CT
2. Inductance OCL: 200uH Min  
@100KHz, 0.1V
3. Insertion Loss:  
1~400MHz: -1.6dB Max
4. Return Loss:  
1~40MHz: -18dB Min  
40~500MHz: -18-10\*LOG(f/40) dB Min
5. Crosstalk:  
1~500MHz: -25dB Min
6. DCMR:  
1~500MHz: -25dB Min
7. Isolation: 1500Vrms.
8. Operating Temperature: -40°C ~ +85°C.



X:X	APPD:	<b>LINK-PP</b>		
X:XX ±0.25	CHKD:	LINK-PP INT'L TECHNOLOGY CO., LIMITED		
X:XXX	DR: TOM	TITLE: 10G Base-T PC Card SMD Transformer Module		
ANGLES ±1°	UNIT: mm	PART NO.: LP7016ANL		
	SCALE: 2/1	SHEET: 2/2	REV: A	DWG NO.: LP11080669