

REV	DESCRIPTION OF CHANGE	REVIEWED BY	ISSUE DATE
A	FIRST ISSUE	James	2021-08-01

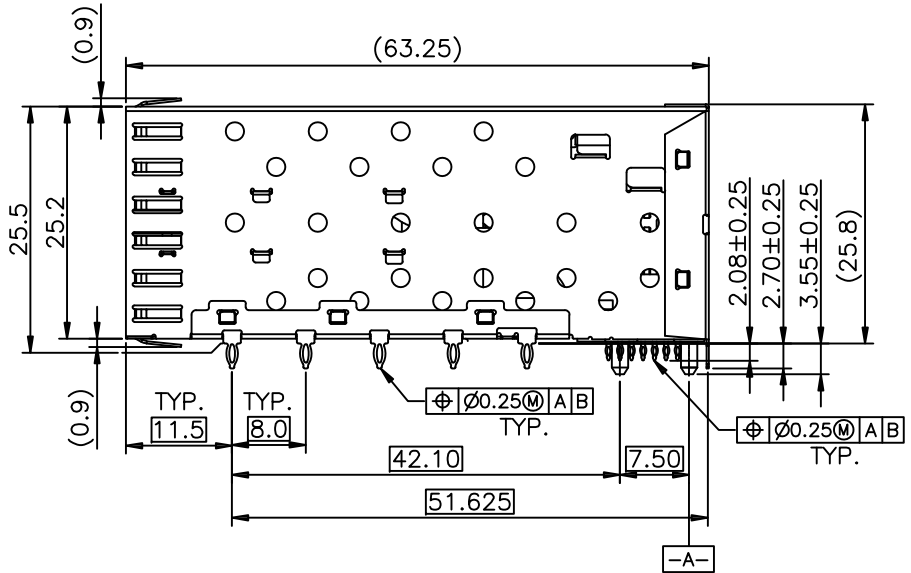

NOTES:

- MATERIAL:
- CAGE: COPPER ALLOY 30u" MIN NI-PLATED, THICKNESS 0.25 MM
- CONNECTOR:
- PLASTIC HOUSING: HIGH TEMPERATURE LCP, UL94 V-0.
- SPRING: STAINLESS STEEL, THICKNESS 0.20mm
- CONTACTS: PHOSPHOR BRONZE, THICKNESS 0.20mm
- PLATING: 15μ" MIN. GOLD ON MATING AREA, 150μ" MIN. MATE TIN ON SOLDER TAILS.
- PACKAGING: TRAY PACKAGING.
- OPERATING TEMPERATURE: -40°C TO +85°C
- STORAGE TEMPERATURE: -55°C TO +105°C

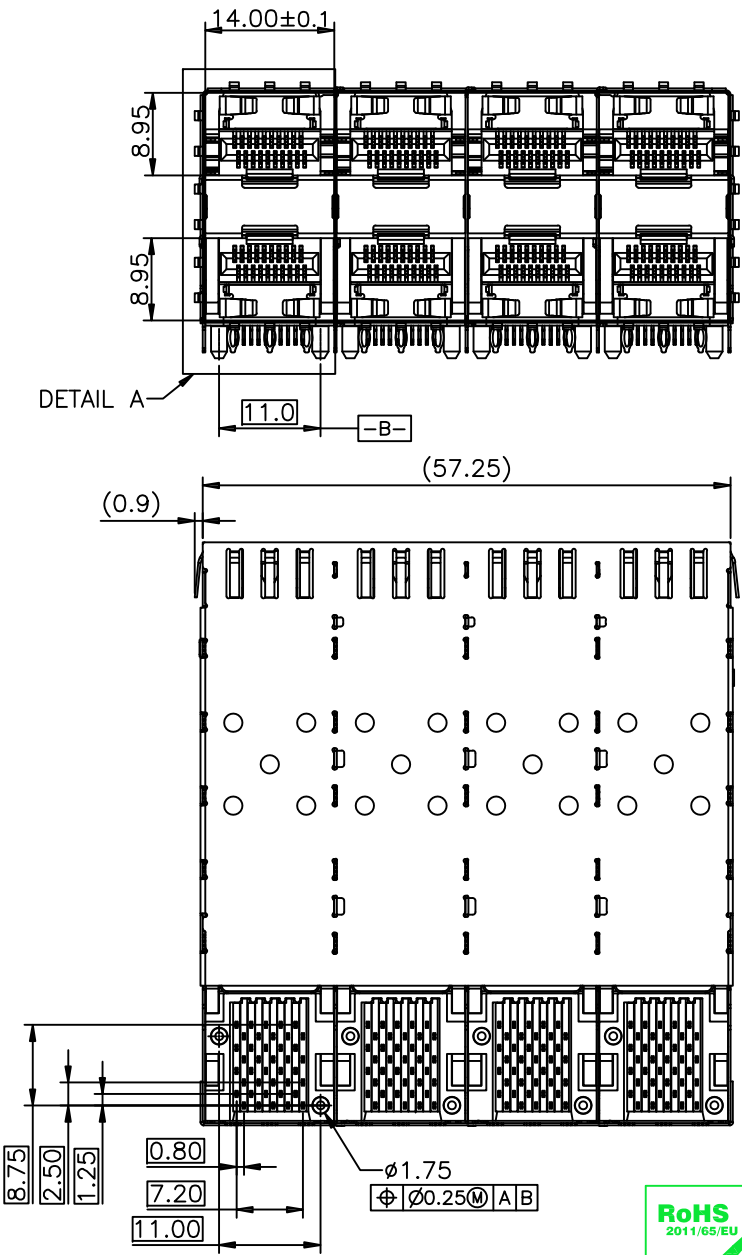

TITLE			LINK-PP INT'L TECHNOLOGY CO., LIMITED			
SFP 2X4 CAGE+CONNECTOR						
PART NO.			GENERAL TOLERANCE		UNIT:MM	SIZE: A4
LP24AC01001						
APPROVE	CHECK	DRAW	.X±0.20	.X±1*	SCALE: 1:1	SHEET:1/4
James	Kevin	Kevin	.XX±0.15	.XX±5*		
			.XXX±0.10			
						REV:A

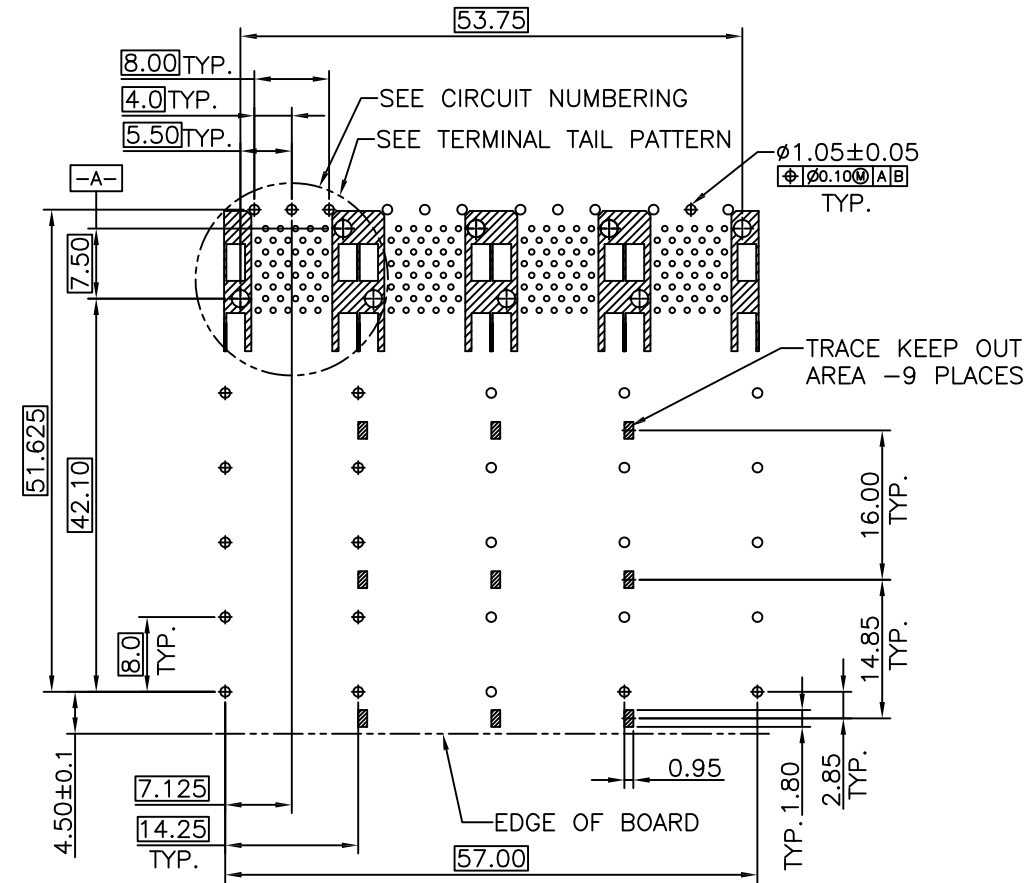
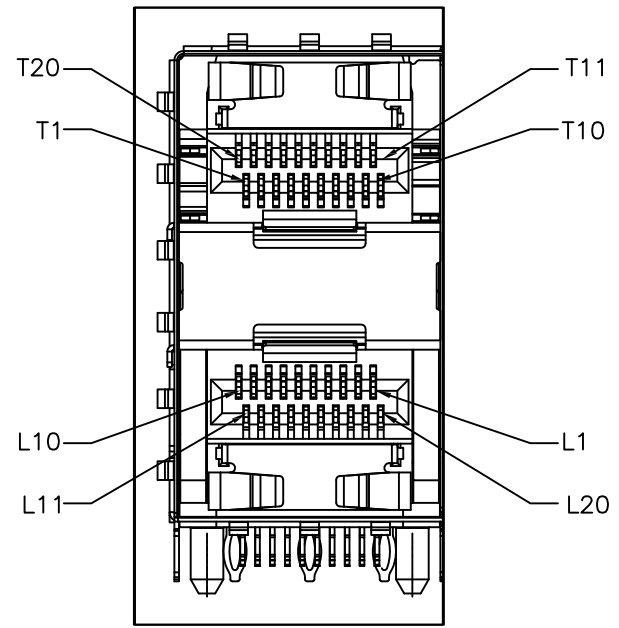
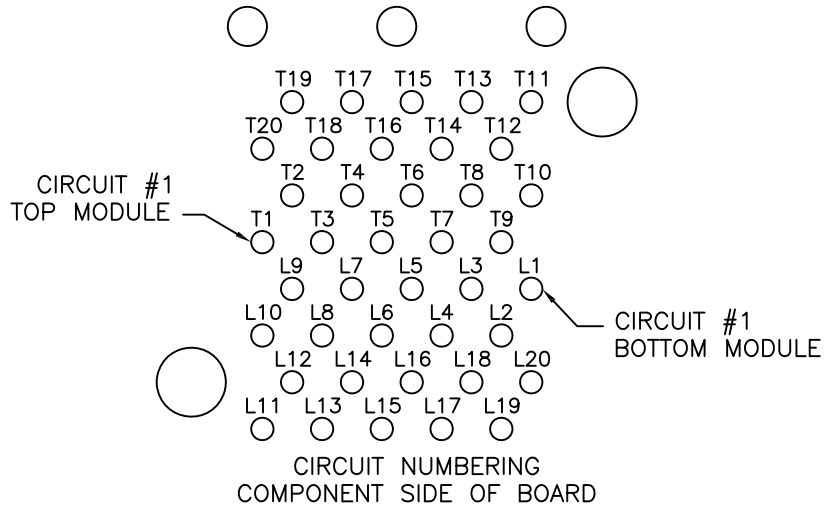

RECOMMENDED PCB LAYOUT - COMPONENT SIDE  
 RECOMMENDED PCB THICKNESS : 2.36MM(.093 INCH)  
 (MINIMUM PCB THICKNESS : 1.57)

THE ENTIRE AREA OF THE CONNECTOR FOOTPRINT  
 TO BE CONSIDERED THE KEEP OUT AREA FOR COMPONENTS  
 THIS AREA IS INDICATED BY THE DASHED LINE



TITLE			SFP 2X4 CAGE+CONNECTOR		LINK-PP INT'L TECHNOLOGY CO., LIMITED				
PART NO.			LP24AC01001		GENERAL TOLERANCE			UNIT:MM	SIZE: A4
APPROVE	CHECK	DRAW	.X±0.20	.X±1'	SCALE: 1:1	SHEET:2/4	REV:A		
James	Kevin	Kevin	.XX±0.15	.XX±5'					
			.XXX±0.10						

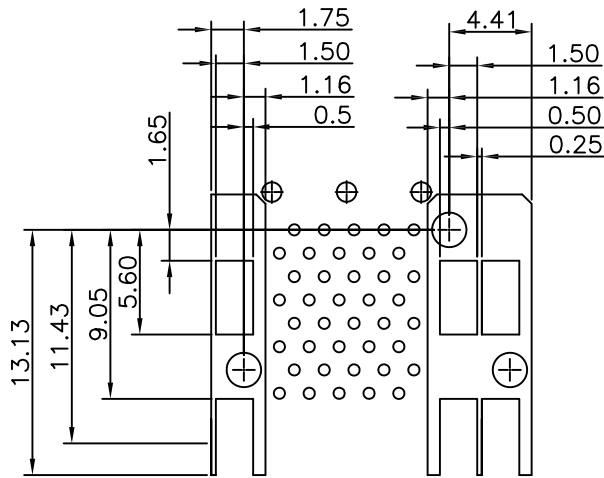

DETAIL-KEEPOUT ZONES

THE HATCHED AREA IN THIS VIEW INDICATES ZONES THAT ARE OCCUPIED BY THE PLASTIC HOUSING THAT SEATS AGAINST THE PCB AND BY THE VERTICAL METAL CAGE WALL THAT STOPS JUST SHORT OF THE PCB

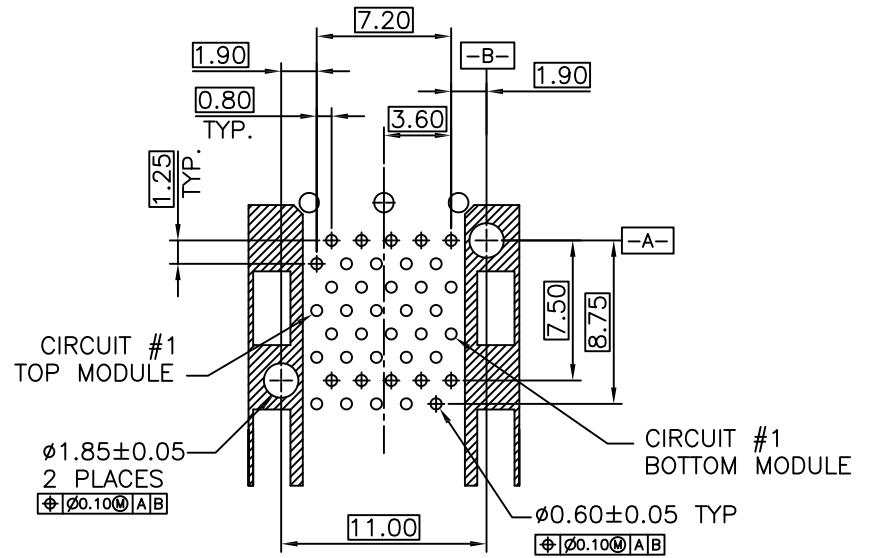

TERMINAL TAIL PATTERN



TITLE			SFP 2X4 CAGE+CONNECTOR		LINK-PP INT'L TECHNOLOGY CO., LIMITED			
PART NO.			LP24AC01001		GENERAL TOLERANCE		UNIT:MM	SIZE: A4
APPROVE	CHECK	DRAW	.X±0.20	.X±1'	SCALE: 1:1		SHEET:3/4	REV:A
James	Kevin	Kevin	.XX±0.15	.XX±5'				
			.XXX±0.10					

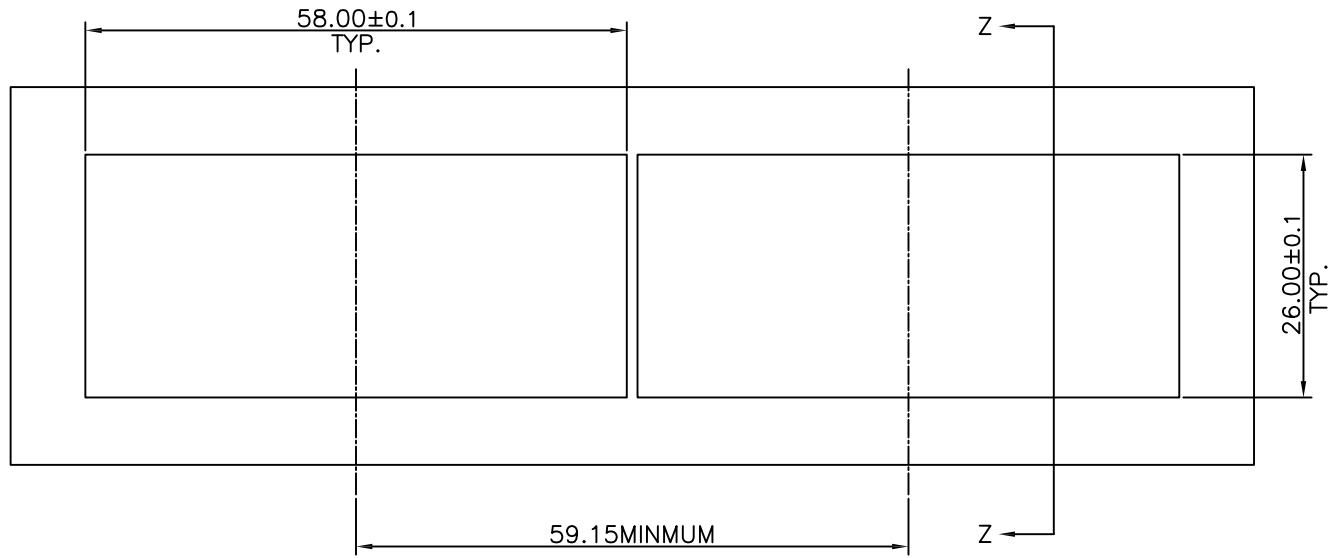

BEZEL CUT-OUT CENTER SPACING DETAIL

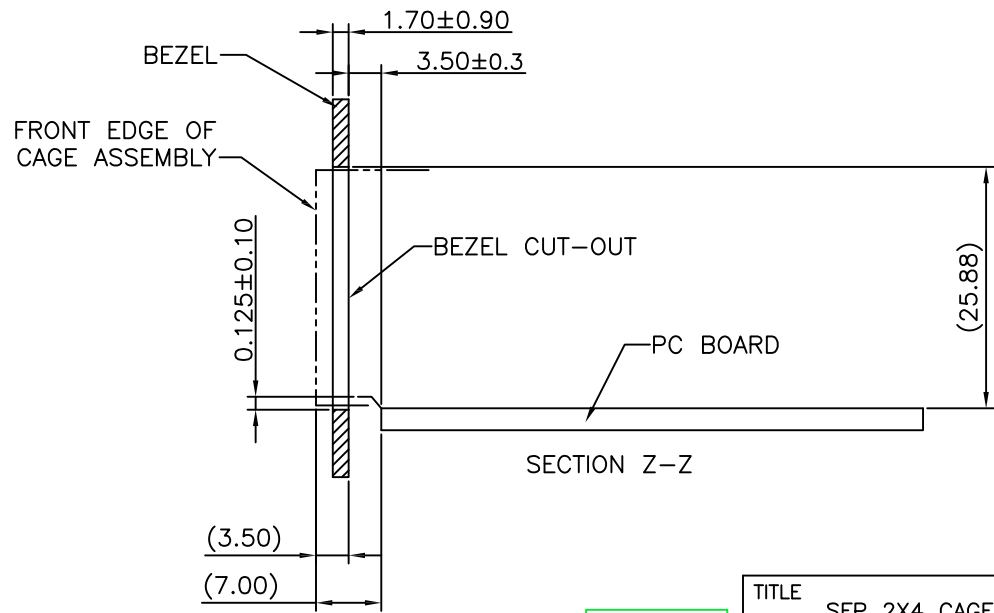

SECTION Z-Z



TITLE			SFP 2X4 CAGE+CONNECTOR		LINK-PP INT'L TECHNOLOGY CO., LIMITED				
PART NO.			LP24AC01001		GENERAL TOLERANCE			UNIT:MM	SIZE: A4
APPROVE	CHECK	DRAW	.X±0.20	.X±1'	SCALE: 1:1		SHEET:4/4	REV:A	
James	Kevin	Kevin	.XX±0.15	.XX±5'					
			.XXX±0.10						