

REV	DESCRIPTION OF CHANGE	REVIEWED BY	ISSUE DATE
A	FIRST ISSUE	LEO	2020-02-03

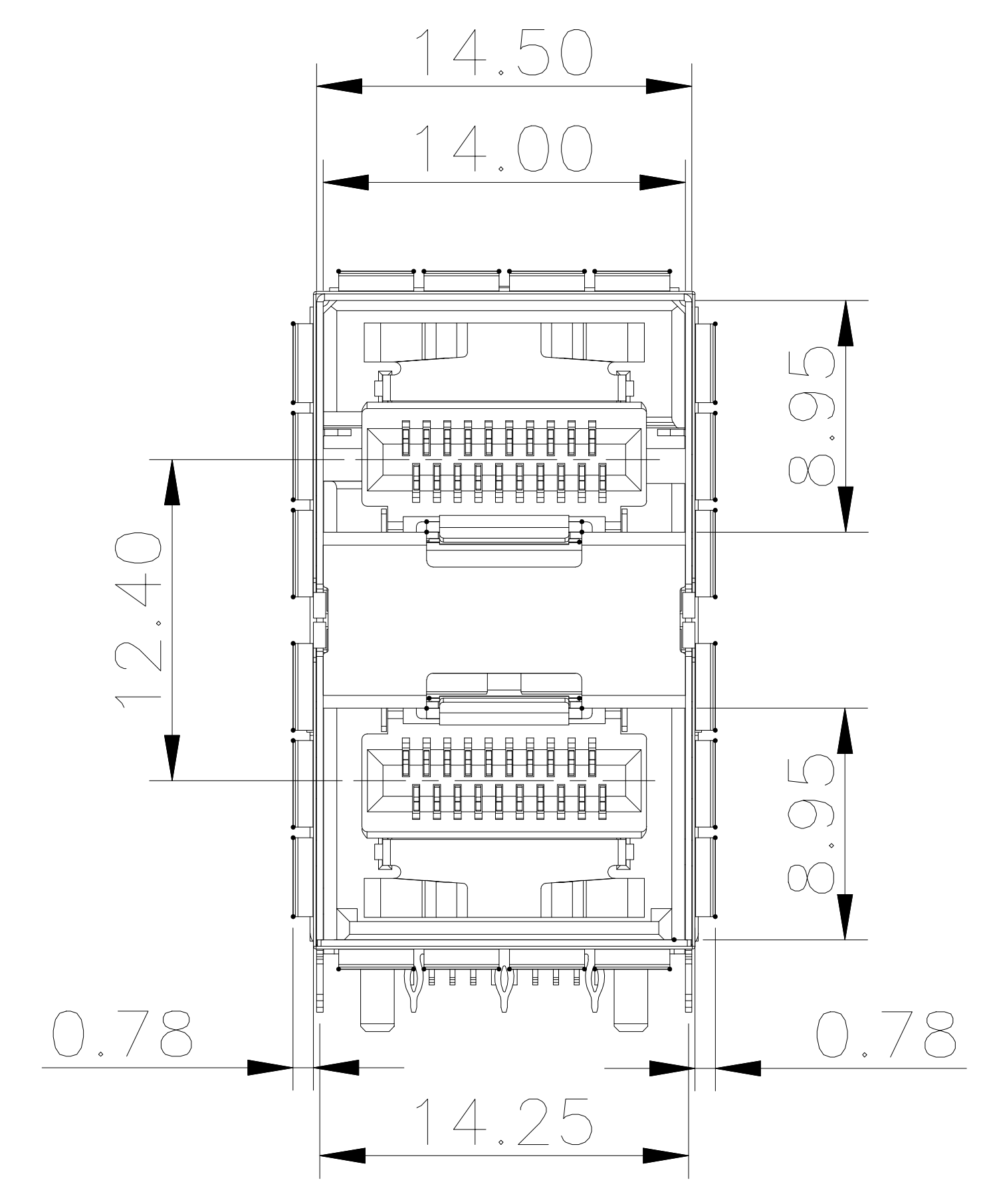

NOTES:
MATERIAL:
CAGE: COPPER ALLOY NI-PLATED, THICKNESS 0.25 MM
CONNECTOR:
PLASTIC HOUSING: HIGH TEMPERATURE LCP, UL94 V-0.
SPRING: STAINLESS STEEL, THICKNESS 0.20mm
CONTACTS: PHOSPHOR BRONZE, THICKNESS 0.20mm
PLATING: 30 μ " MIN. GOLD ON MATING AREA,
150 μ " MIN. MATE TIN ON SOLDER TAILS.
PACKAGING: TRAY PACKAGING.
TEMPERATURE RANGE: -40°C TO +85°C

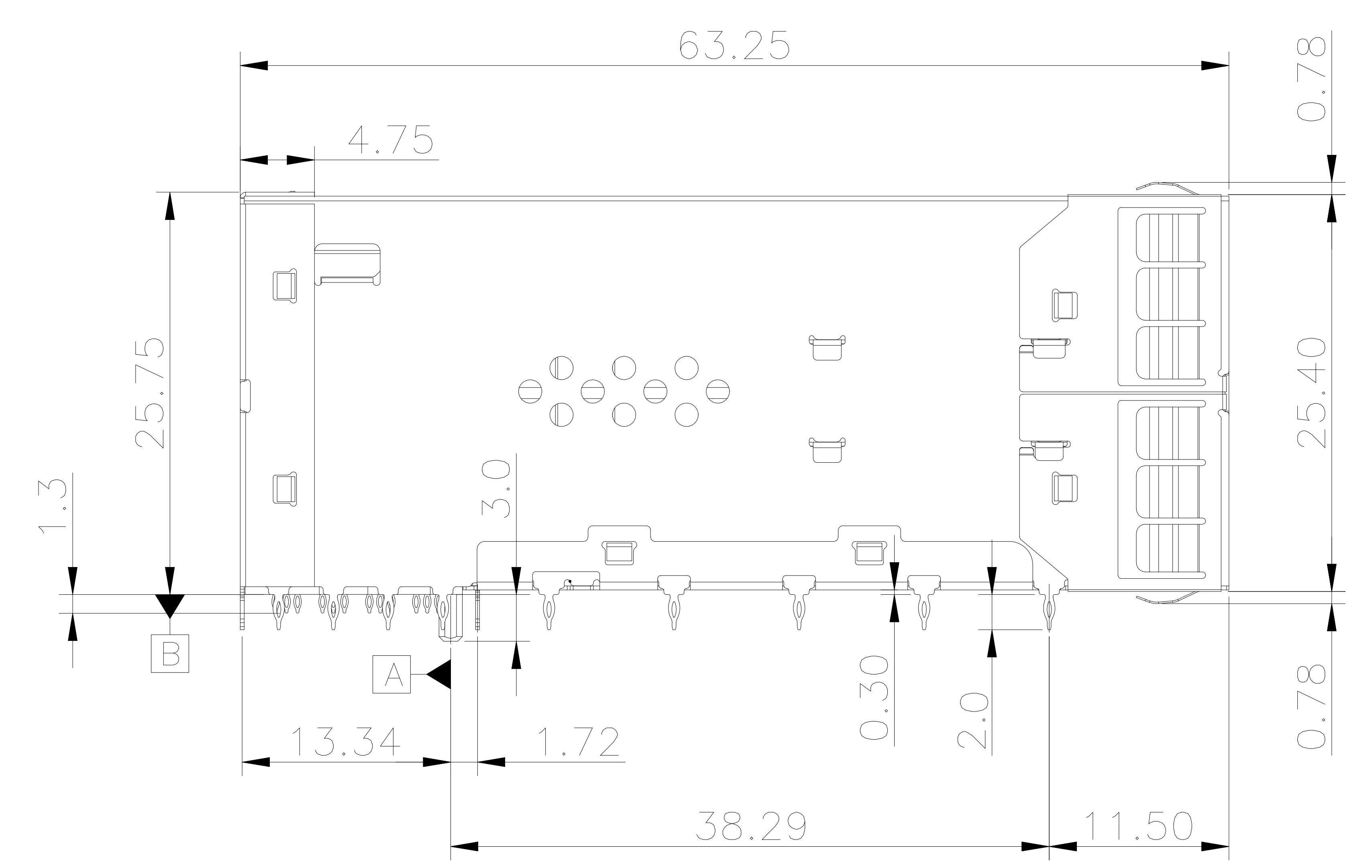
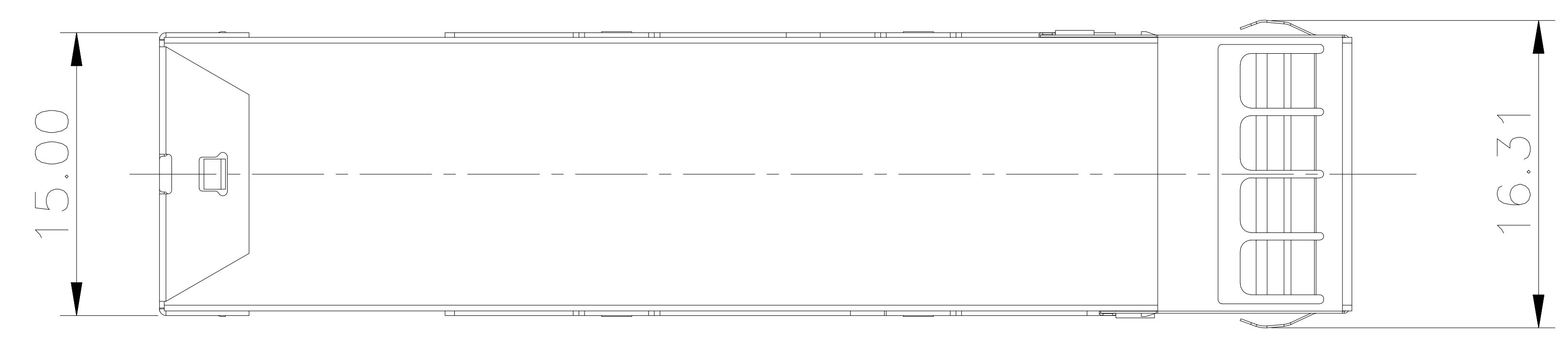
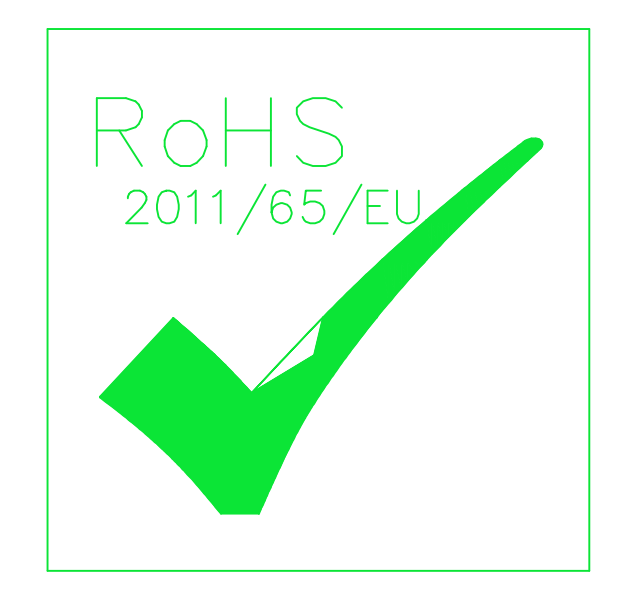

TITLE			LINK-PP INT'L TECHNOLOGY CO., LIMITED			
SFP28 2X1 CAGE & CONNECTOR WITH EMI SPRING FINGER						
PART NO.			GENNERAL TOLERANCE		UNIT:MM	SIZE:A4
LP21CC01003			ϕ X \pm 0.20 ϕ XX \pm 0.15 ϕ XXX \pm 0.10		SCALE:1:1	SHEET:1/4
APPROVE	CHECK	DRAW	ϕ X \pm 1°	ϕ XX \pm 5°	REV:A	
LEO	JAMES	JAMES				

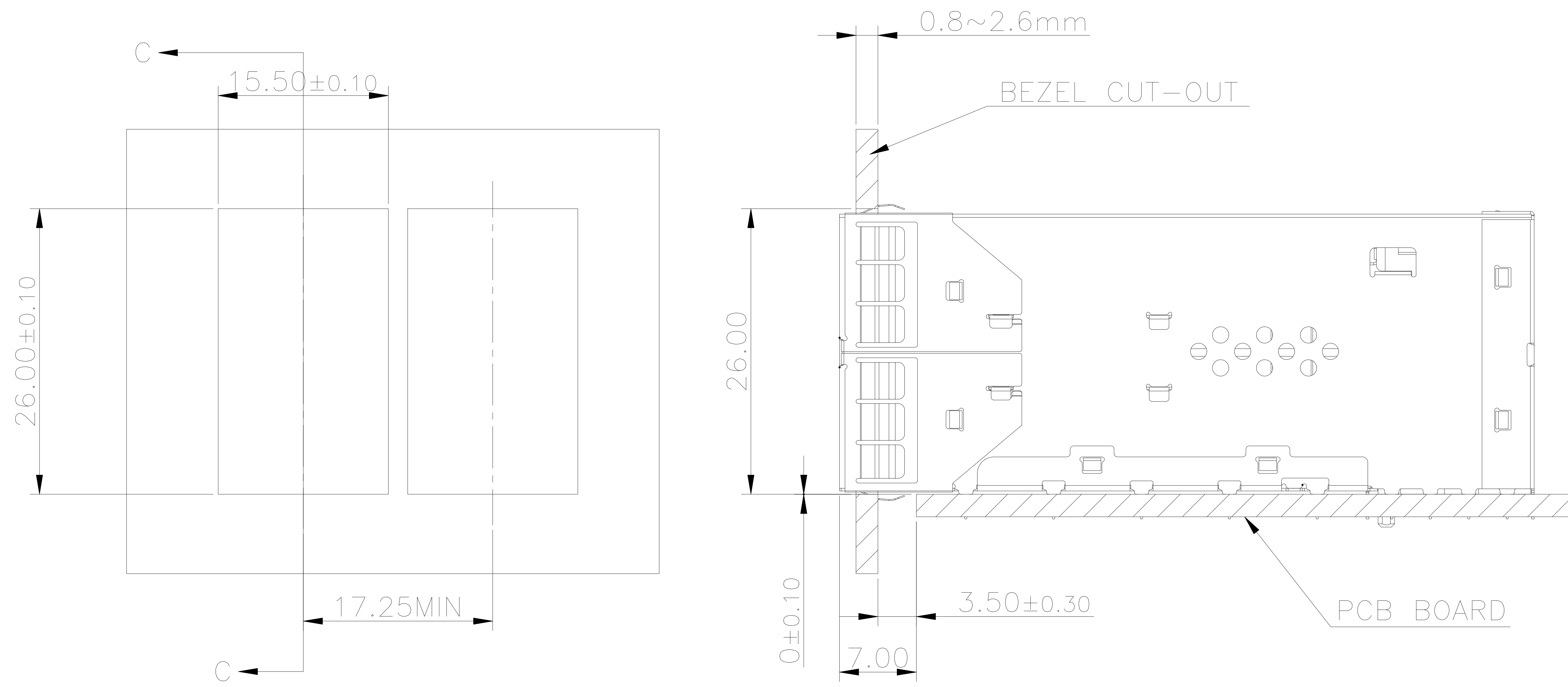

BEZEL CUT-OUT CENTER SPACING DETAIL
BEZEL THICKNESS:0.8-2.6



TITLE			SFP28 2X1 CAGE & CONNECTOR WITH EMI SPRING FINGER		LINK-PP INT'L TECHNOLOGY CO., LIMITED				
PART NO.			LP21CC01003		GENNERAL TOLERANCE			UNIT:MM	SIZE:A4
APPROVE	CHECK	DRAW	° X±0.20	° X±1°	SCALE:1:1		SHEET:2/4	REV:A	
LEO	JAMES	JAMES	° XX±0.15	° XX±5°					
			° XXX±0.10						

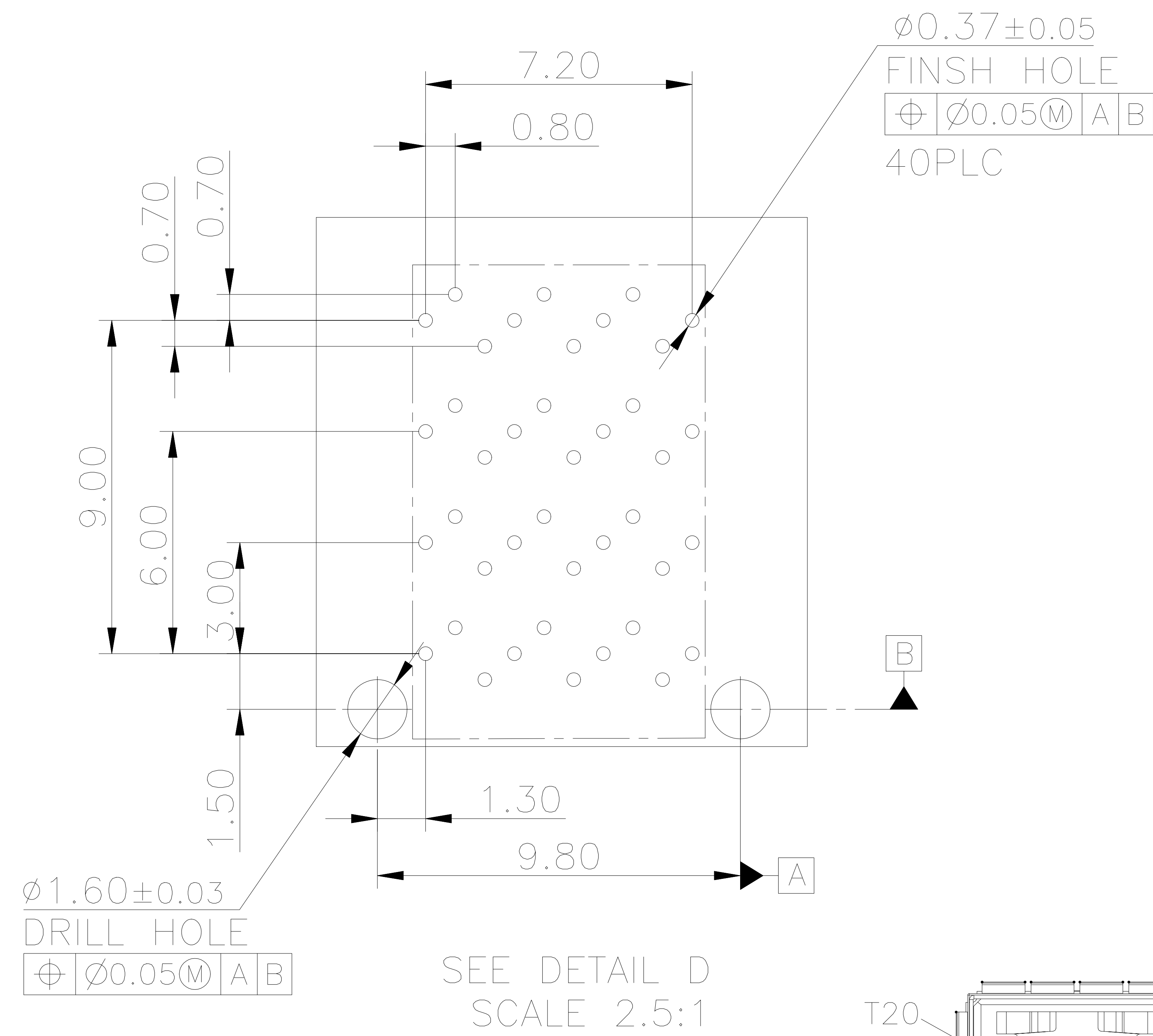

PIN MAP

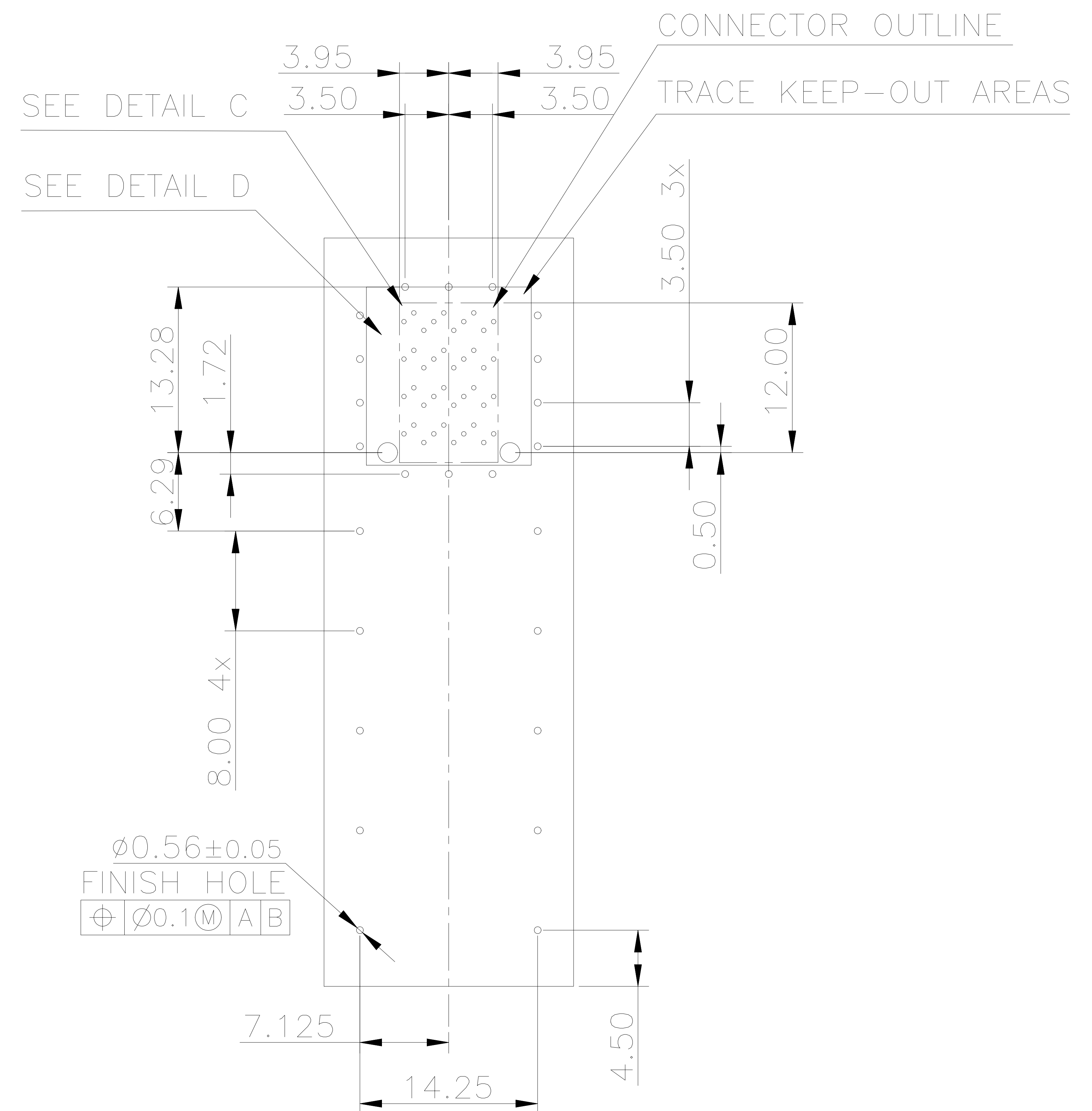
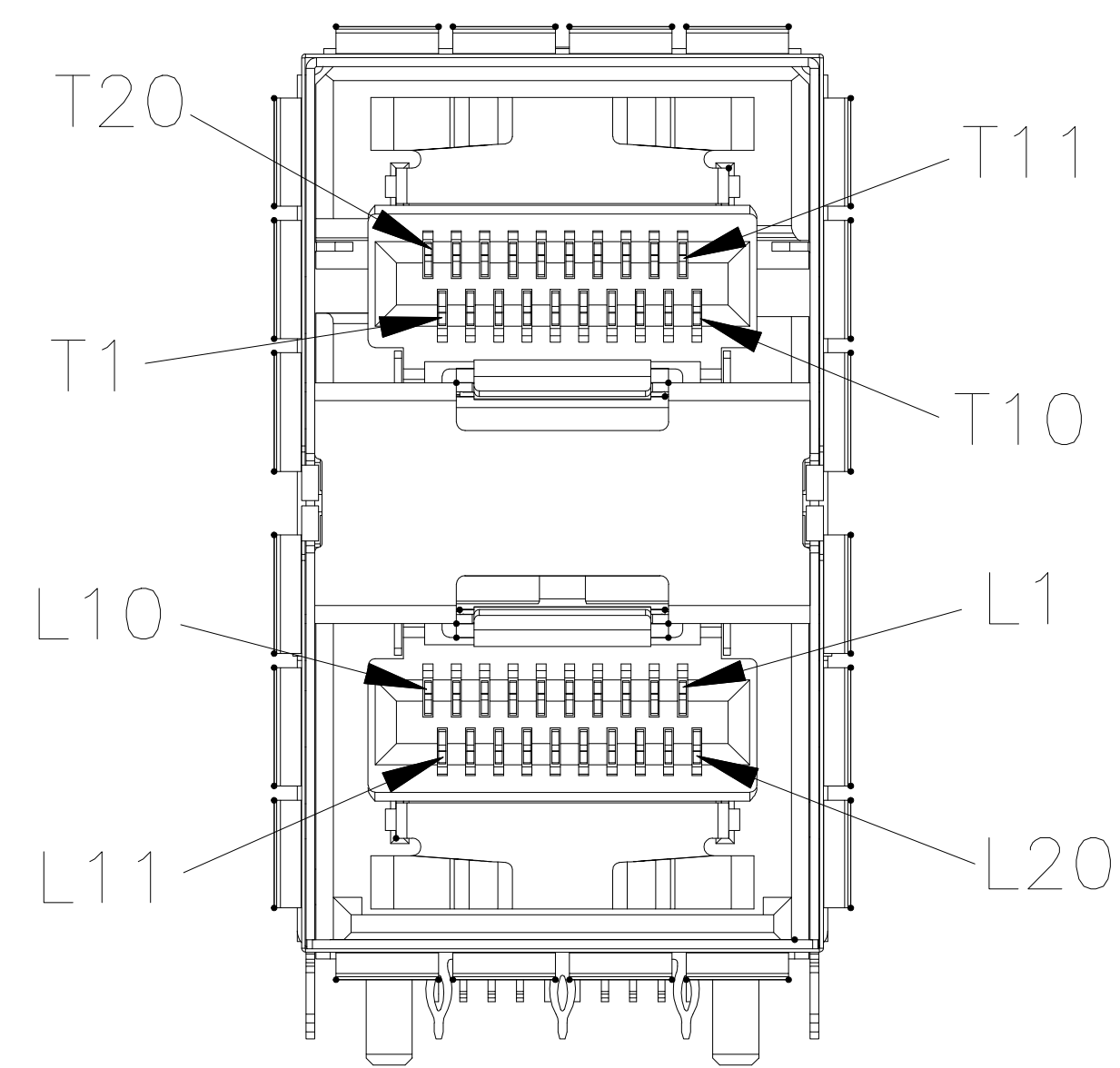
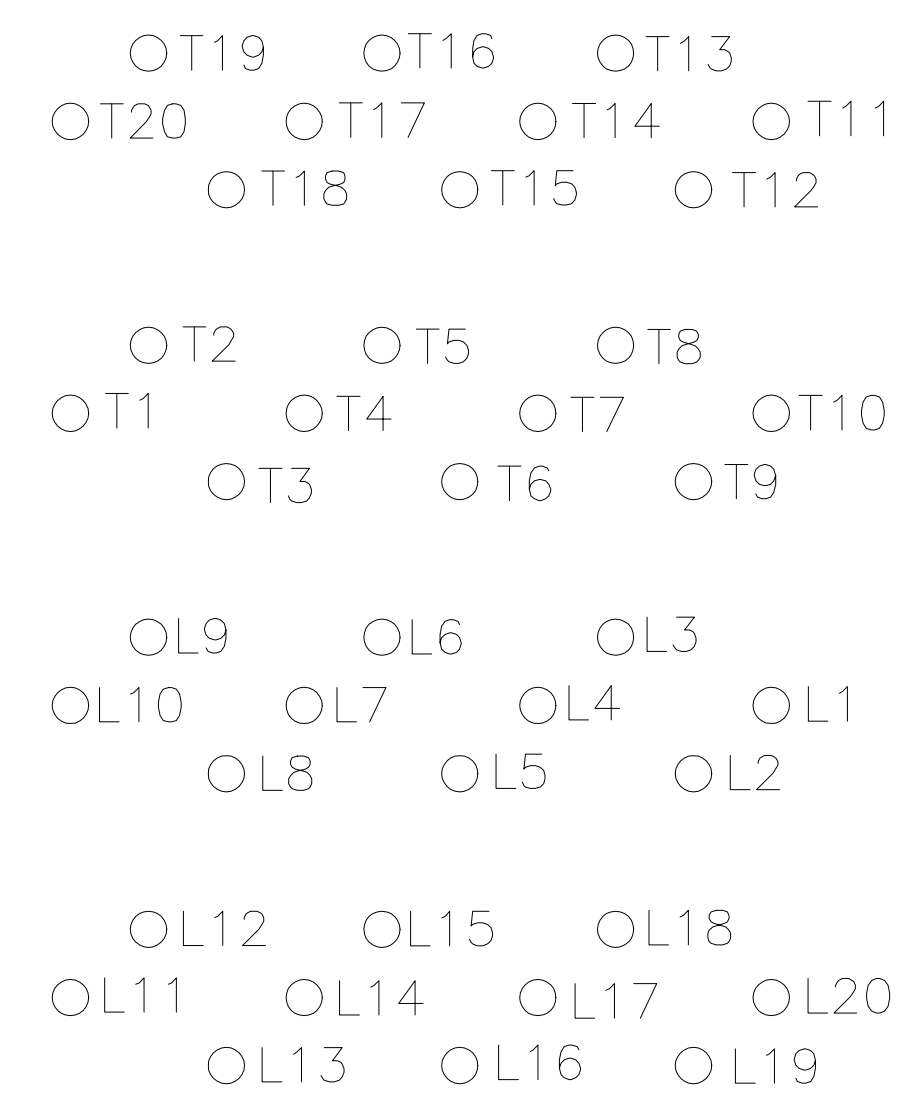

TITLE			SFP28 2X1 CAGE & CONNECTOR WITH EMI SPRING FINGER		LINK-PP INT'L TECHNOLOGY CO., LIMITED			
PART NO.			LP21CC01003		GENNERAL TOLERANCE		UNIT:MM	SIZE:A4
APPROVE	CHECK	DRAW	. X±0.20	. X±1°	SCALE:1:1	SHEET:3/4	REV:A	
LEO	JAMES	JAMES	. XX±0.15	. XX±5°				
			. XXX±0.10					

PACKAGE INFORMATION AND LABEL

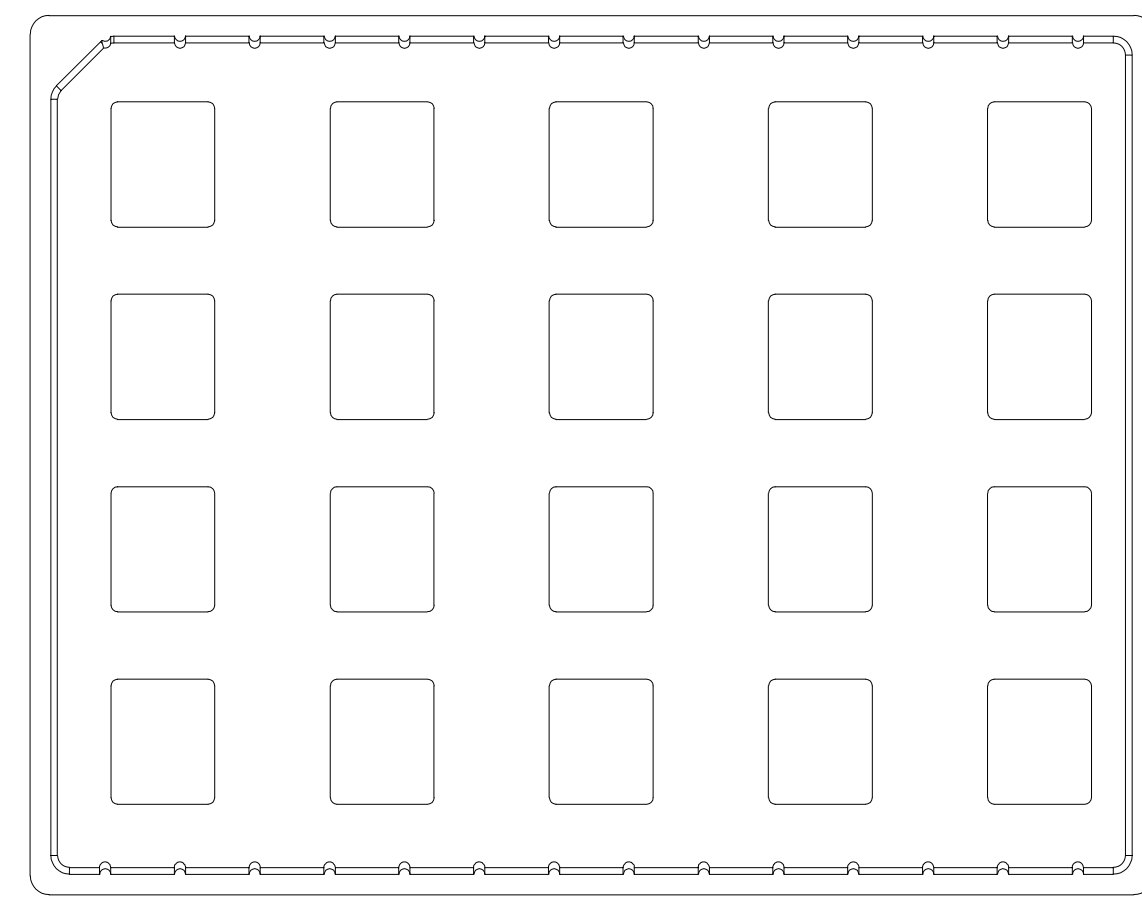

1. 24PCS PRODUCTS IN TRAYS

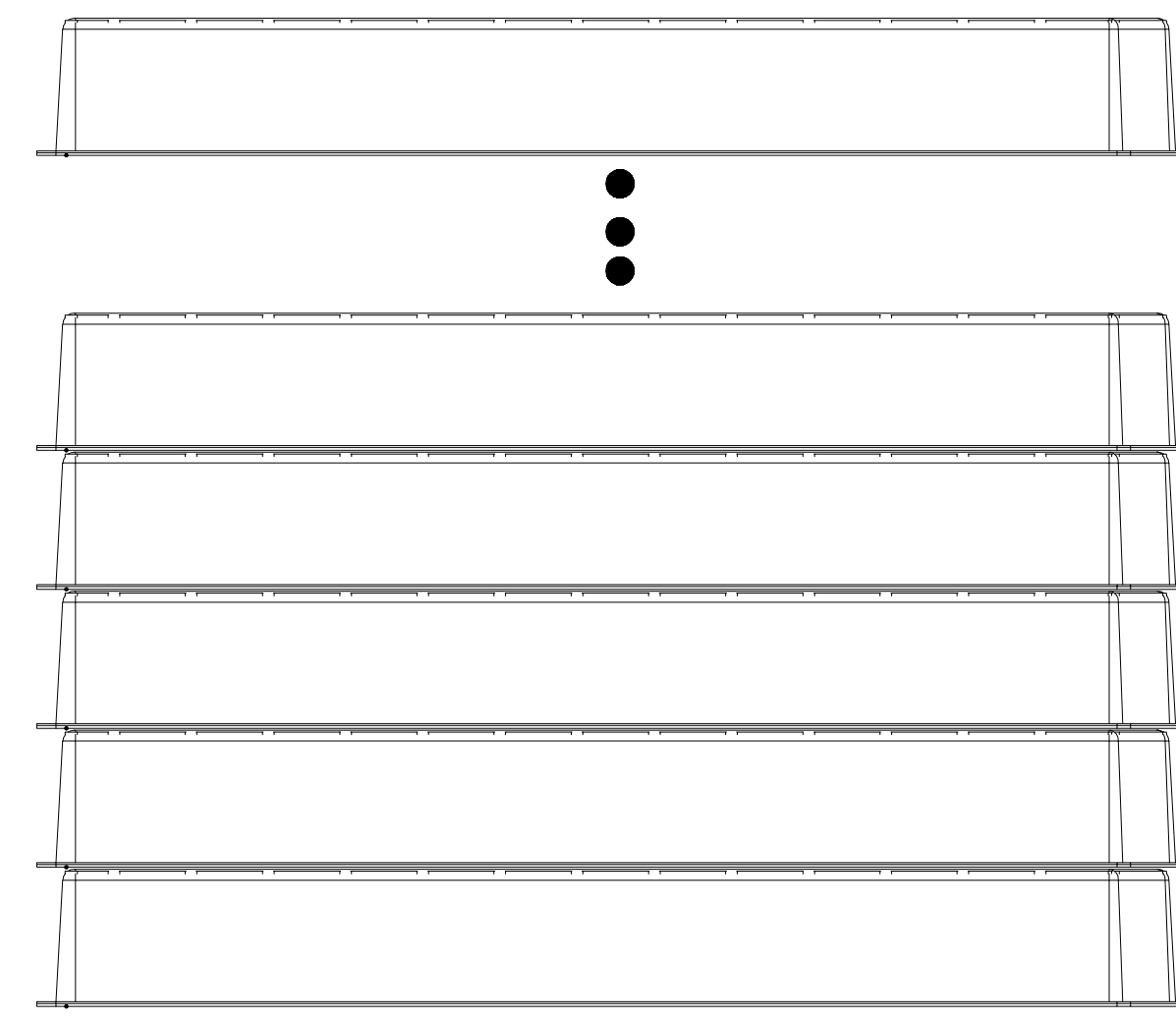
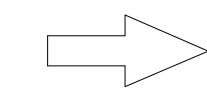

2. TRAYS OVERLAY:
(THE NEXT TRAY NEED ROTATE 180 DEGREE AND PUT IT ON PREVIOUS TRAY.)

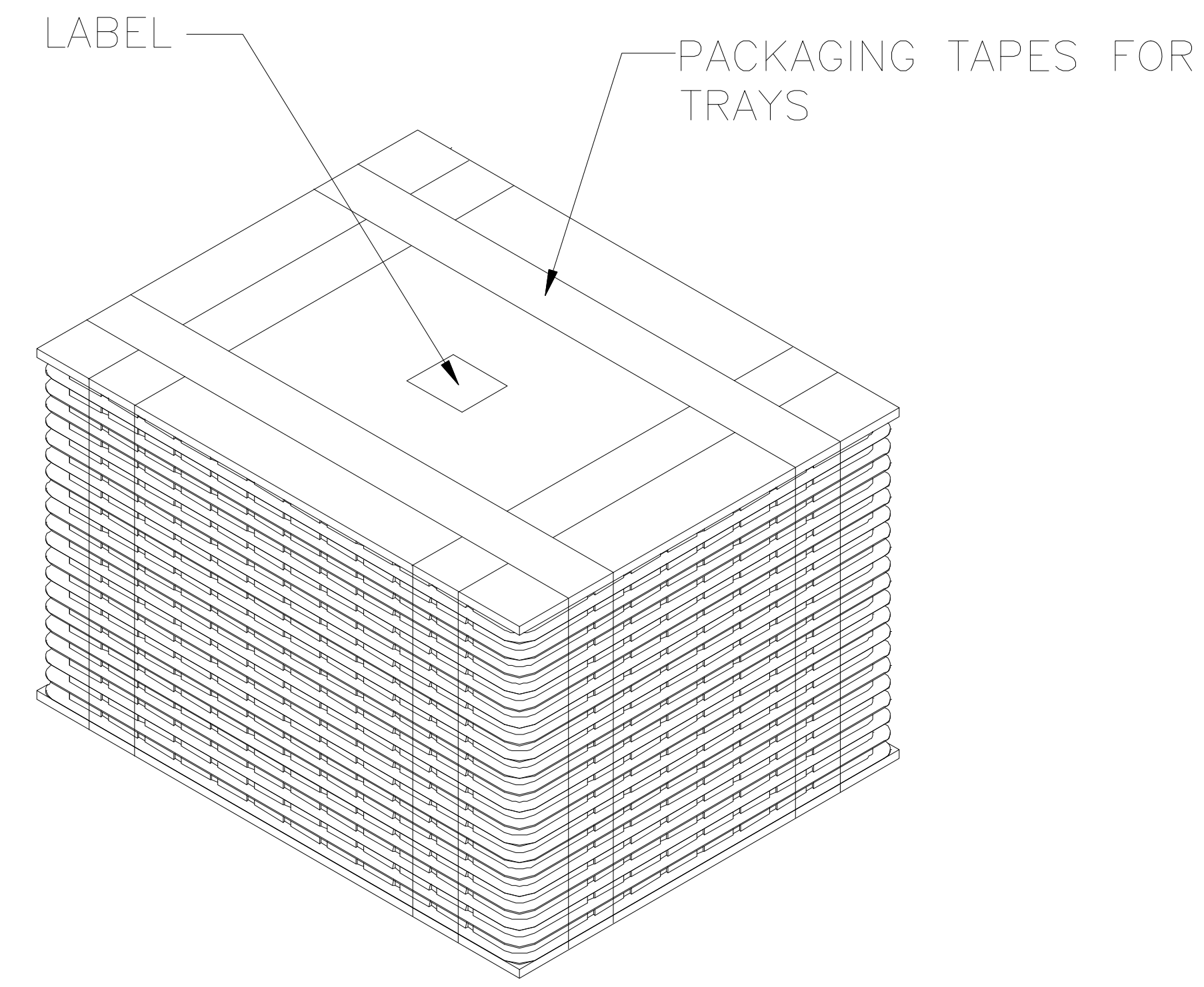
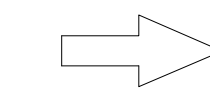

3. LABEL & PACKAGING TAPES FOR TRAYS:

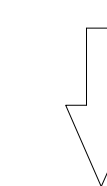

4. LABEL & PACKAGING TAPES FOR BOX

Packing information:

- 1. One plate: 24PCS
- 2. A box of 240PCS
- 3. Outer box size: 34*32*28CM
- 4. Gross weight of one case: 8.5KG

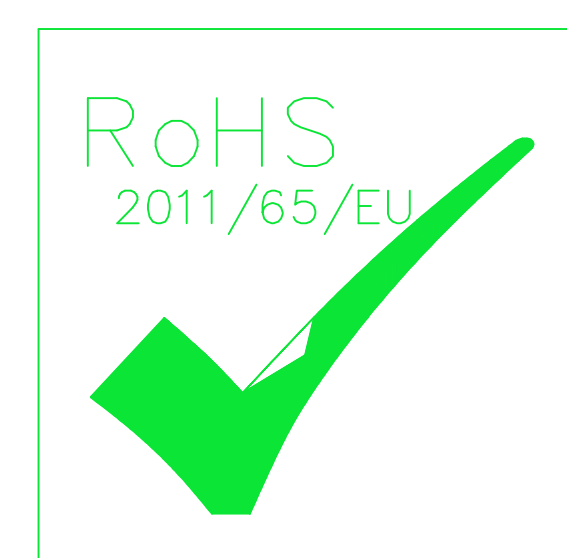

TITLE			SFP28 2X1 CAGE & CONNECTOR WITH EMI SPRING FINGER		LINK-PP INT'L TECHNOLOGY CO., LIMITED			
PART NO.			LP21CC01003		GENNERAL TOLERANCE		UNIT:MM	SIZE:A4
APPROVE	CHECK	DRAW	° X±0.20	° X±1°	 SCALE:1:1	SHEET:4/4	REV:A	
LEO	JAMES	JAMES	° XX±0.15	° XX±5°				
			° XXX±0.10					