

REV	DESCRIPTION OF CHANGE	REVIEWED BY	ISSUE DATE
A	FIRST ISSUE	James	2021-08-01

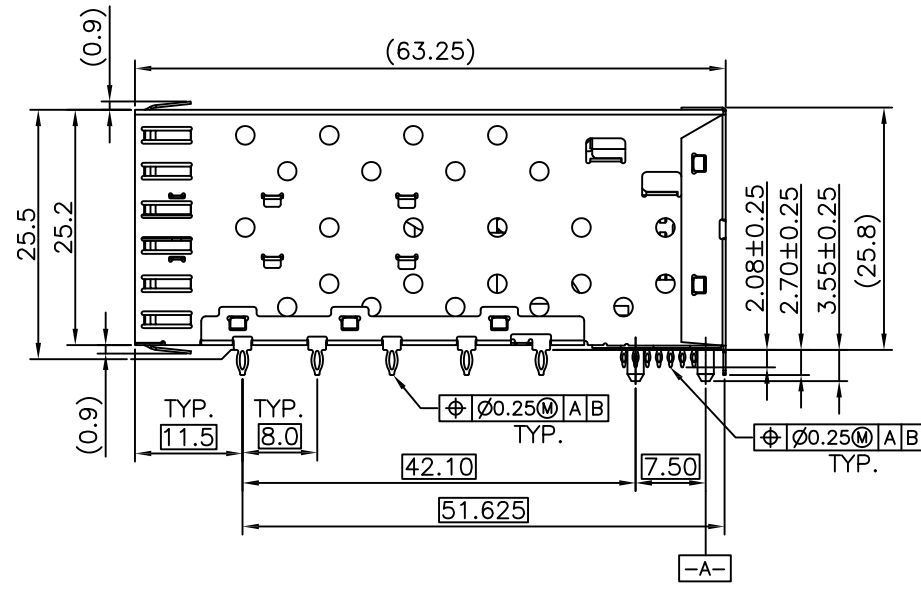

NOTES:

MATERIAL:
 CAGE: COPPER ALLOY 30u" MIN NI-PLATED, THICKNESS 0.25 MM
 CONNECTOR:
 PLASTIC HOUSING: HIGH TEMPERATURE LCP, UL94 V-0.
 SPRING: STAINLESS STEEL, THICKNESS 0.20mm
 CONTACTS: PHOSPHOR BRONZE, THICKNESS 0.20mm
 PLATING: 15μ" MIN. GOLD ON MATING AREA,
 150μ" MIN. MATE TIN ON SOLDER TAILS.
 PACKAGING: TRAY PACKAGING.
 TEMPERATURE RANGE: -40°C TO +85°C
 STORAGE TEMPERATURE: -55°C TO +105°C

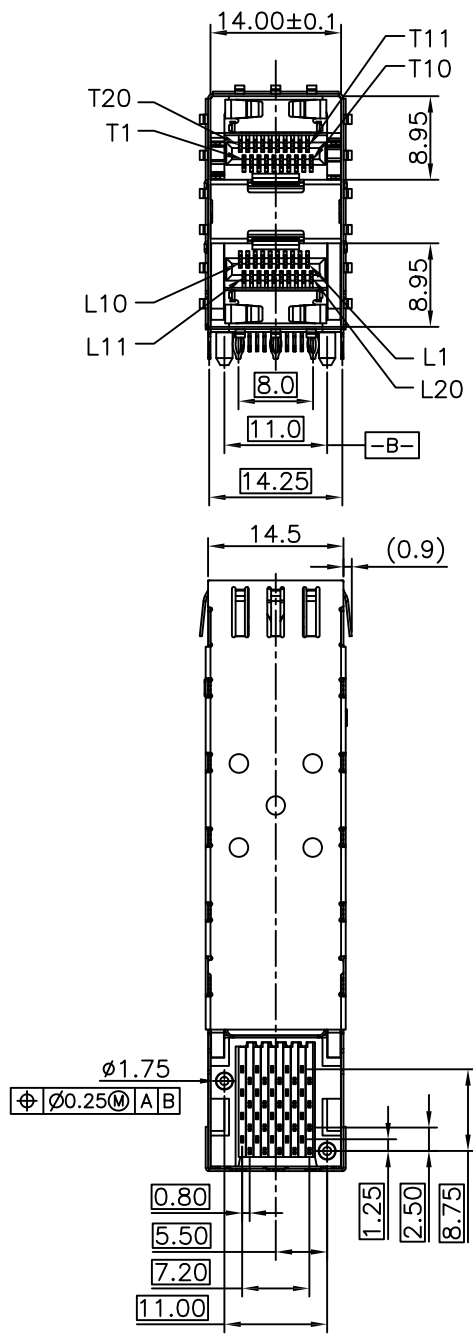

TITLE			LINK-PP INT'L TECHNOLOGY CO., LIMITED		
SFP 2X1 CAGE+CONNECTOR					
PART NO.			GENERAL TOLERANCE		UNIT:MM
LP21AC01001			.X±0.20 .X±1'		SIZE: A4
APPROVE	CHECK	DRAW	.XX±0.15 .XX±5'	SCALE: 1:1	SHEET:1/3
James	Kevin	Kevin	.XXX±0.10		

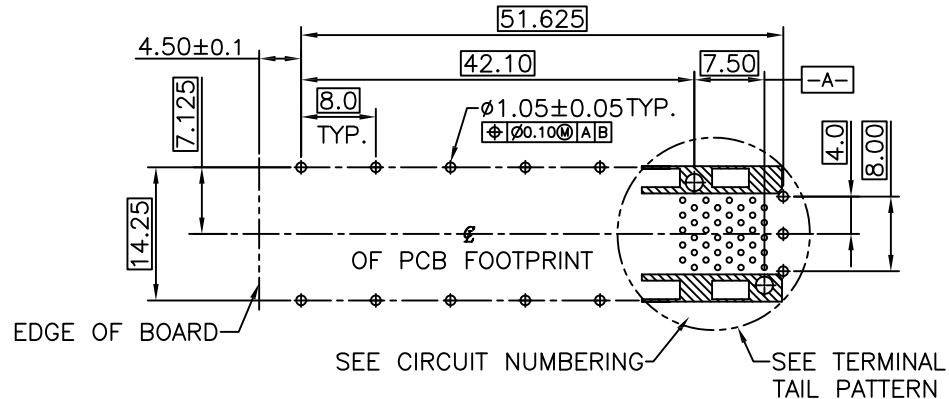

RECOMMENDED PCB LAYOUT – COMPONENT SIDE
 RECOMMENDED PCB THICKNESS : 2.36MM(.093 INCH)
 (MINIMUM PCB THICKNESS : 1.57)

THE ENTIRE AREA OF THE CONNECTOR FOOTPRINT
 TO BE CONSIDERED THE KEEP OUT AREA FOR COMPONENTS
 THIS AREA IS INDICATED BY THE DASHED LINE

L11	L10	T1	T20
⊕ L12	⊕ L9	⊕ T2	⊕ T19
⊕ L13	⊕ L8	⊕ T3	⊕ T18
⊕ L14	⊕ L7	⊕ T4	⊕ T17
⊕ L15	⊕ L6	⊕ T5	⊕ T16
⊕ L16	⊕ L5	⊕ T6	⊕ T15
⊕ L17	⊕ L4	⊕ T7	⊕ T14
⊕ L18	⊕ L3	⊕ T8	⊕ T13
⊕ L19	⊕ L2	⊕ T9	⊕ T12
⊕ L20	⊕ L1	⊕ T10	⊕ T11

CIRCUIT NUMBERING
 COMPONENT SIDE OF BOARD

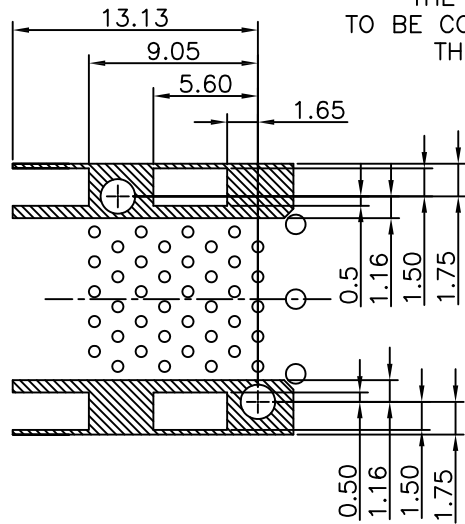

DETAIL-KEEPOUT ZONES

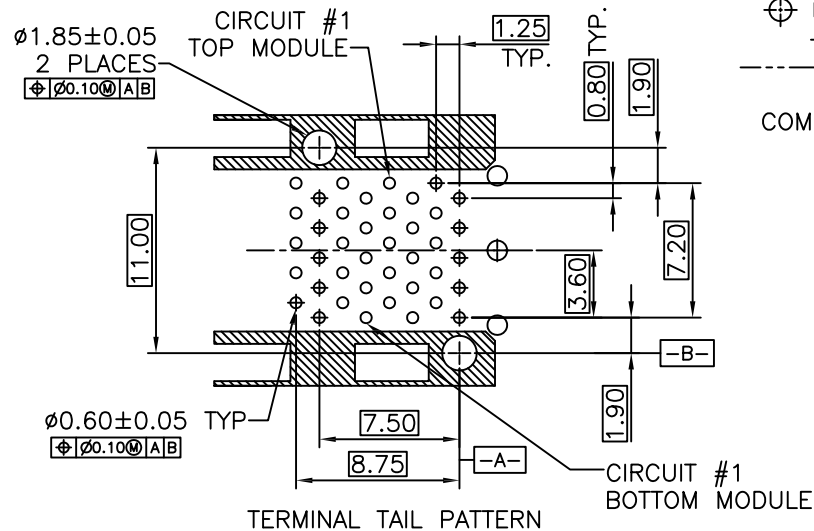

TERMINAL TAIL PATTERN

THE HATCHED AREA IN THIS VIEW INDICATES ZONES
 THAT ARE OCCUPIED BY THE PLASTIC HOUSING THAT
 SEATS AGAINST THE PCB AND BY THE VERTICAL METAL
 CAGE WALL THAT STOPS JUST SHORT OF THE PCB



TITLE			LINK-PP INT'L TECHNOLOGY CO., LIMITED		
SFP 2X1 CAGE+CONNECTOR					
PART NO.			GENERAL TOLERANCE		UNIT:MM
LP21AC01001			.X±0.20 .X±1'		SIZE: A4
APPROVE	CHECK	DRAW	SCALE: 1:1		SHEET:2/3
James	Kevin	Kevin	.XX±0.15 .XX±5'		REV:A
			.XXX±0.10		

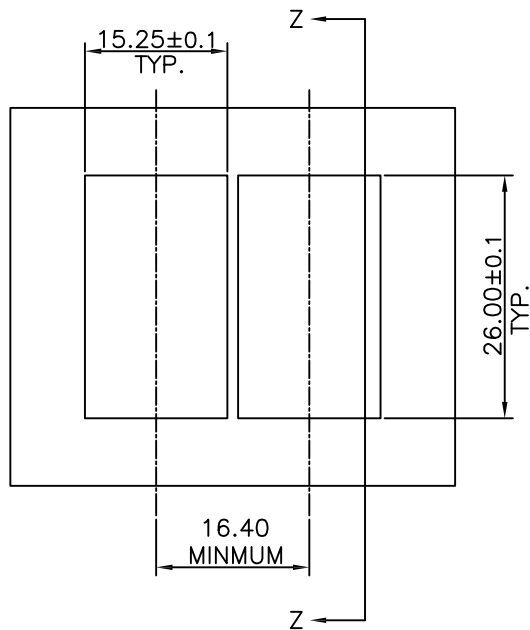

BEZEL CUT-OUT CENTER SPACING DETAIL

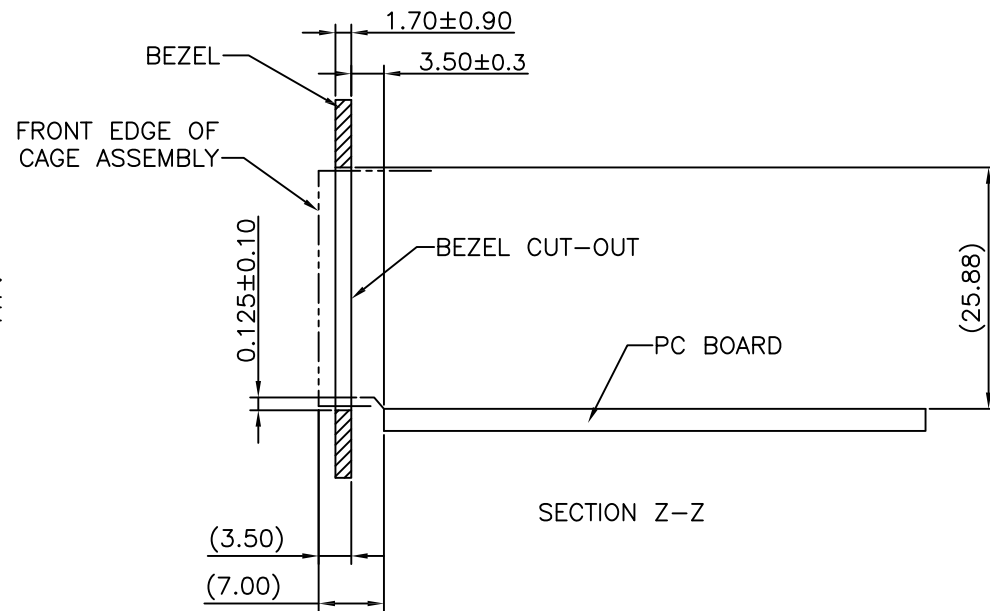

SECTION Z-Z



TITLE			SFP 2X1 CAGE+CONNECTOR		LINK-PP INT'L TECHNOLOGY CO., LIMITED				
PART NO.			LP21AC01001		GENERAL TOLERANCE			UNIT:MM	SIZE: A4
APPROVE	CHECK	DRAW	.X±0.20	.X±1'	SCALE: 1:1		SHEET:3/3	REV:A	
James	Kevin	Kevin	.XX±0.15	.XX±5'					
			.XXX±0.10						