

REV	DESCRIPTION OF CHANGE	REVIEWED BY	ISSUE DATE
A	FIRST ISSUE	LEO	2021-10-13

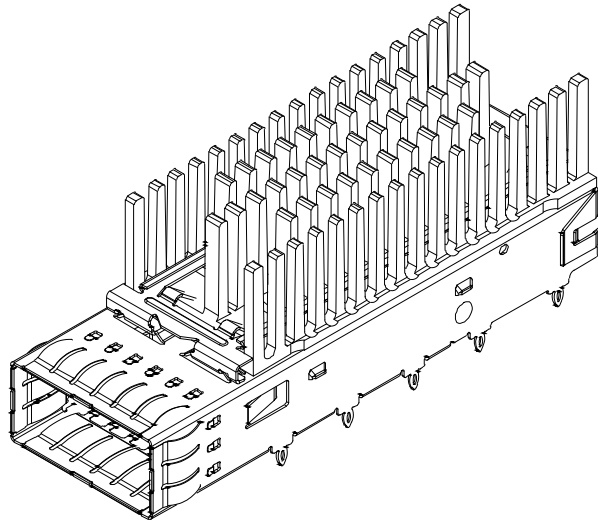

1. MATERIALS:
 BODY CAGE: STAINLESS STEEL, 0.25 THICKNESS
 EMI FINGER: STAINLESS STEEL
 HEATSINK: ALUMINUM
 HEATSINK CLIP: STAINLESS STEEL
2. SURFACE FINISH:
 BODY CAGE: CLEANING
 EMI SPRING: CLEANING AND HOLE SEALING
 HEATSINK: BLACK ANODIZED
 HEATSINK CLIP: CLEANING
3. MATE WITH QSFP MSA COMPATIBLE TRANSCEIVER.
4. REFERENCE DOCUMENTS:
 PRODUCT SPECIFICATION: QSFP MSA
5. THIS PRODUCT COMPLY TO ROHS DIRECTIVE 2011/65/EU.

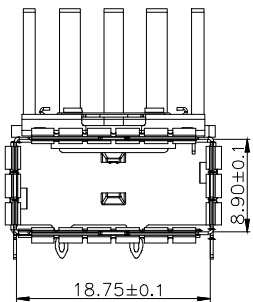
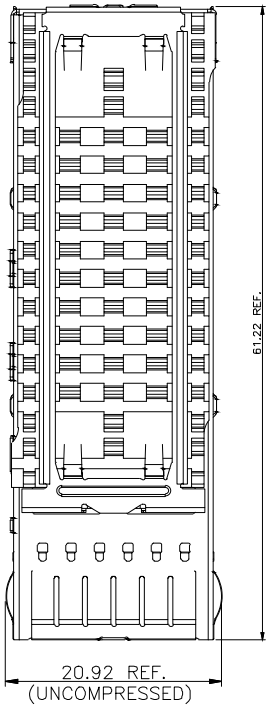
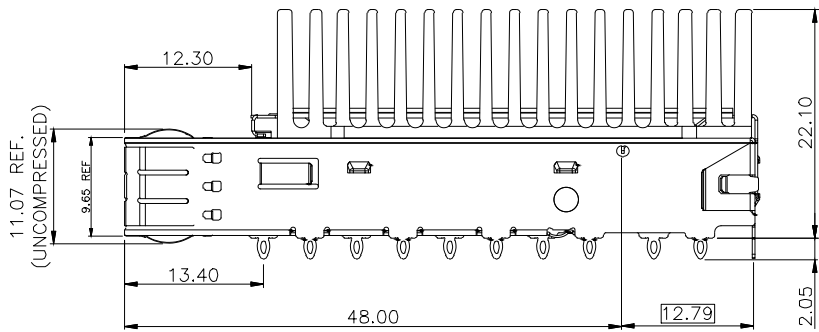

TITLE QSFP28 1X1 CAGE WITH EMI SPRING FINGER HEAT SINK			LINK-PP INT'L TECHNOLOGY CO., LIMITED		
PART NO. LP11FC010G0D			GENNERAL TOLERANCE		UNIT:MM
APPROVE	CHECK	DRAW	° X±0.20	° X±1°	SIZE:A4
LEO	JAMES	JAMES	° XX±0.15	° XX±5°	REV:A
			° XXX±0.10	SCALE:1:1	SHEET:1/4

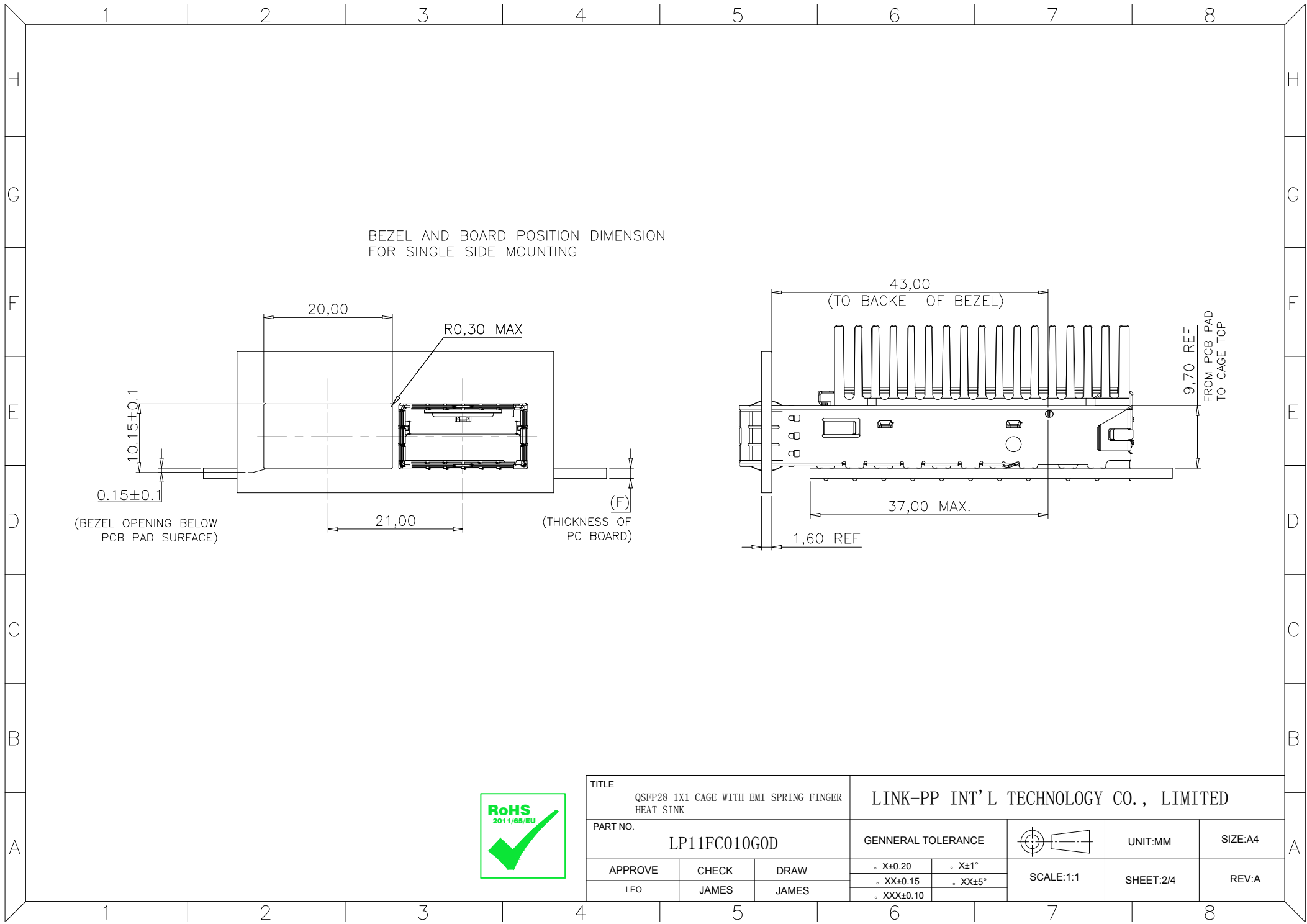

BEZEL AND BOARD POSITION DIMENSION
FOR SINGLE SIDE MOUNTING

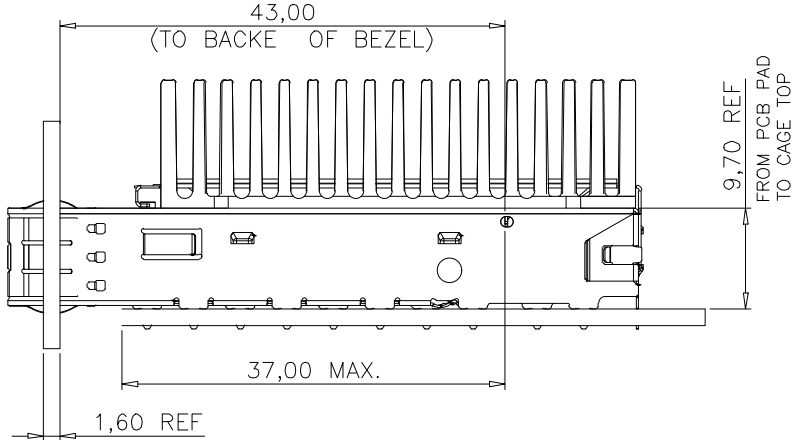
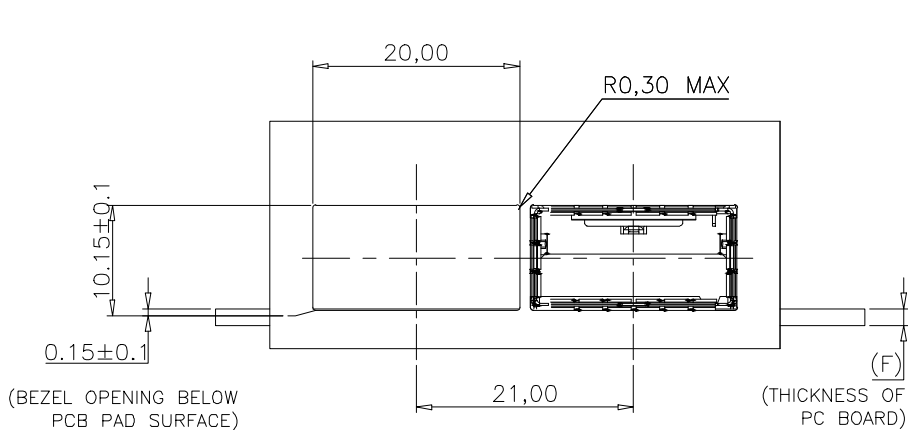

TITLE			QSP28 1X1 CAGE WITH EMI SPRING FINGER HEAT SINK		LINK-PP INT'L TECHNOLOGY CO., LIMITED			
PART NO.			LP11FC010G0D		GENNERAL TOLERANCE		UNIT:MM	SIZE:A4
APPROVE	CHECK	DRAW	. X±0.20	. X±1°	SCALE:1:1		SHEET:2/4	REV:A
LEO	JAMES	JAMES	. XX±0.15	. XX±5°				
			. XXX±0.10					

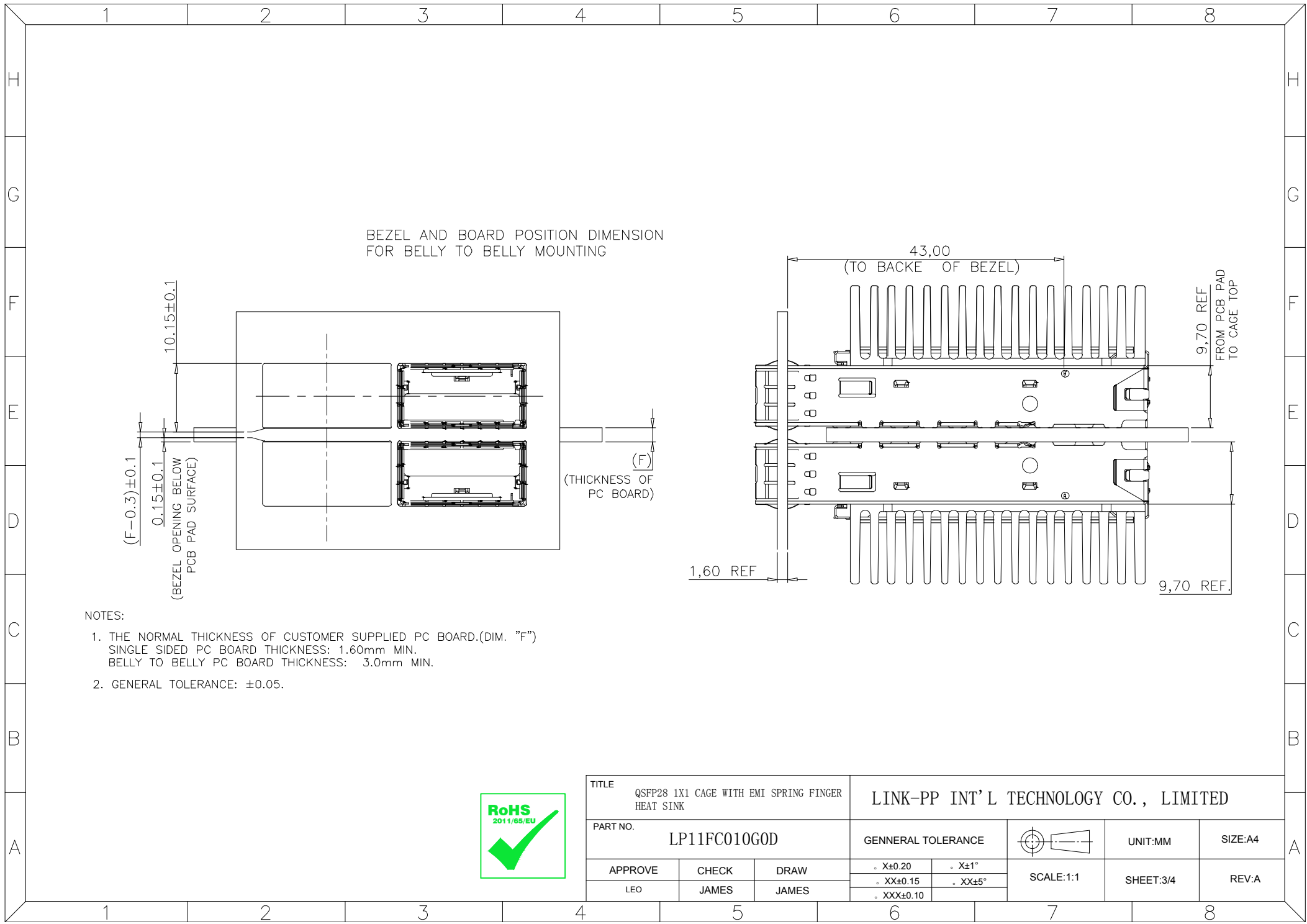

BEZEL AND BOARD POSITION DIMENSION FOR BELLY TO BELLY MOUNTING

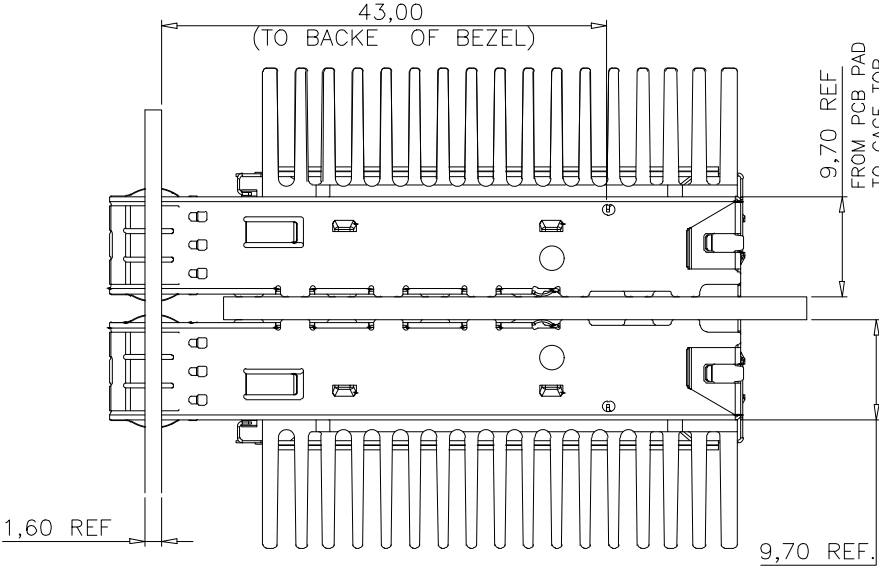
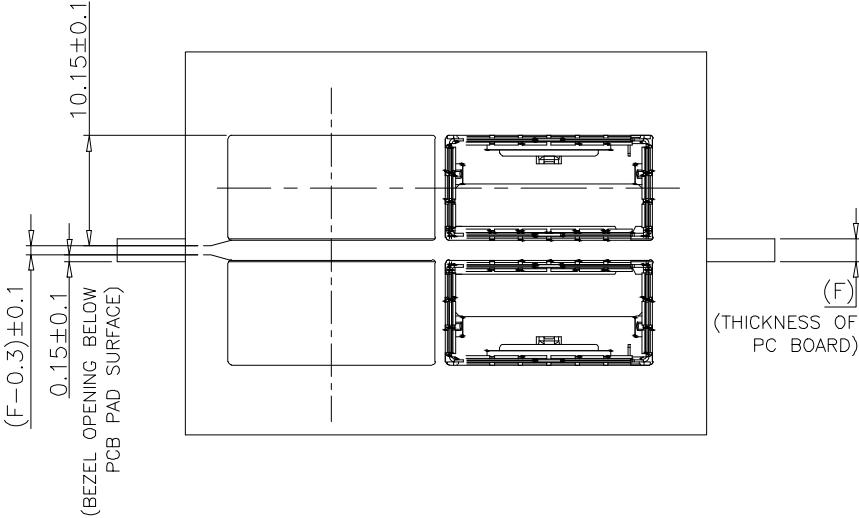

NOTES:

1. THE NORMAL THICKNESS OF CUSTOMER SUPPLIED PC BOARD.(DIM. "F")
 SINGLE SIDED PC BOARD THICKNESS: 1.60mm MIN.
 BELLY TO BELLY PC BOARD THICKNESS: 3.0mm MIN.
2. GENERAL TOLERANCE: ±0.05.



TITLE			QSFP28 1X1 CAGE WITH EMI SPRING FINGER HEAT SINK		LINK-PP INT'L TECHNOLOGY CO., LIMITED			
PART NO.			LP11FC010G0D		GENNERAL TOLERANCE		UNIT:MM	SIZE:A4
APPROVE	CHECK	DRAW	• X±0.20	• X±1°	SCALE:1:1	SHEET:3/4	REV:A	
LEO	JAMES	JAMES	• XX±0.15	• XX±5°				
			• XXX±0.10					

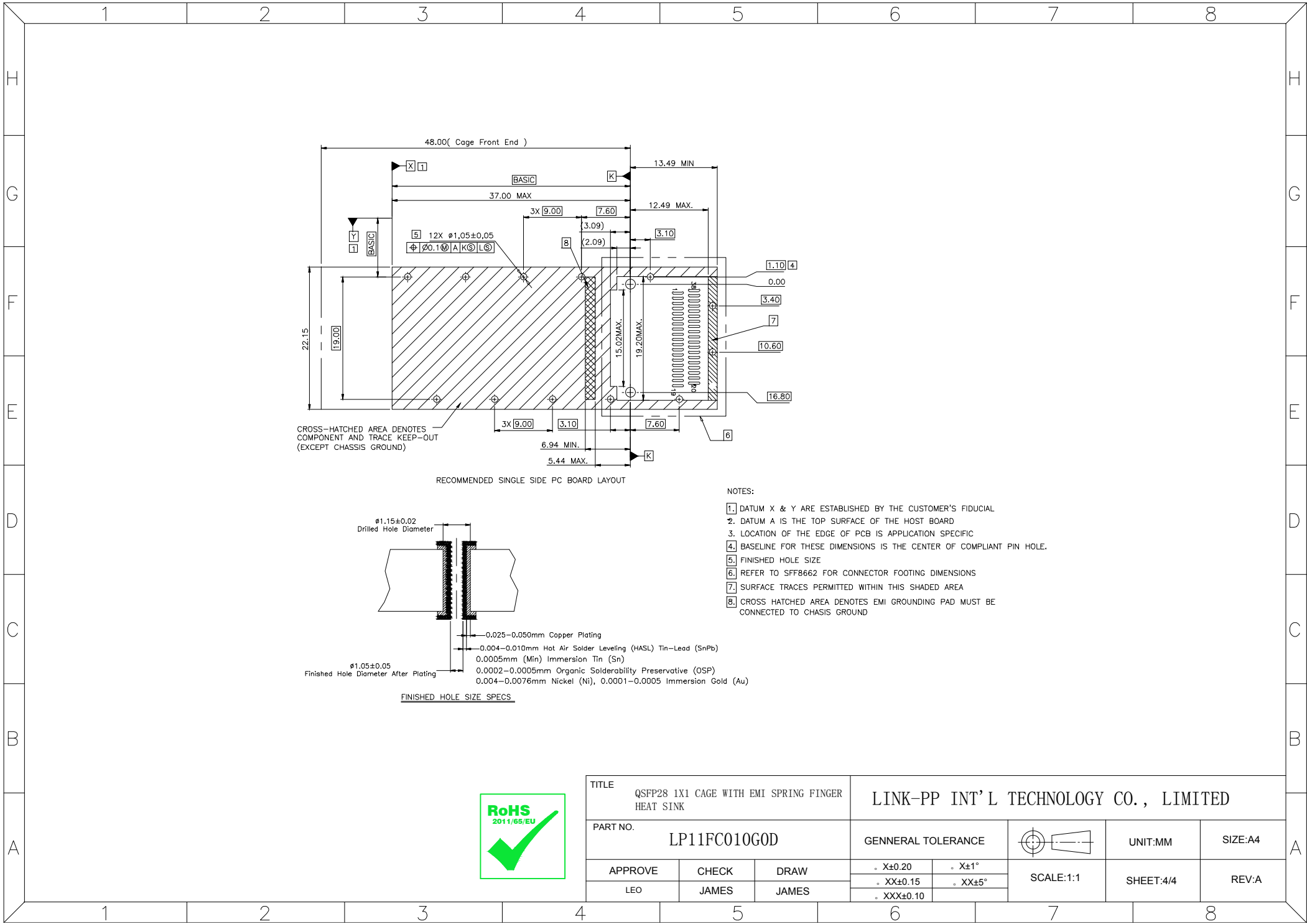

TITLE			QSF28 1X1 CAGE WITH EMI SPRING FINGER HEAT SINK		LINK-PP INT'L TECHNOLOGY CO., LIMITED			
PART NO.			LP11FC010G0D		GENNERAL TOLERANCE		UNIT:MM	SIZE:A4
APPROVE	CHECK	DRAW	. X±0.20	. X±1°	SCALE:1:1	SHEET:4/4	REV:A	
LEO	JAMES	JAMES	. XX±0.15	. XX±5°				
			. XXX±0.10					