

REV	DESCRIPTION OF CHANGE	REVIEWED BY	ISSUE DATE
A	FIRST ISSUE	James	2021-08-01

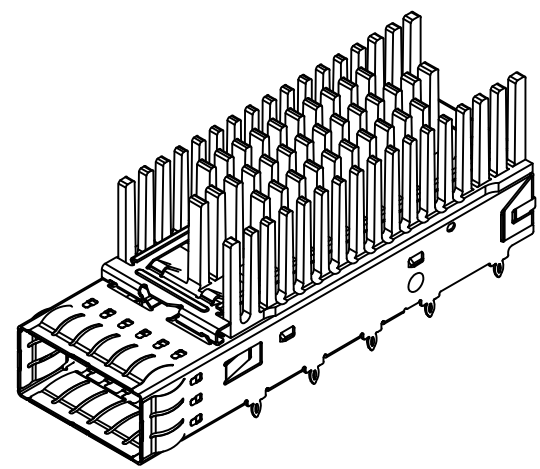

- MATERIALS:
 BODY CAGE: STAINLESS STEEL, 0.25 THICKNESS
 EMI FINGER: STAINLESS STEEL
 HEATSINK: ALUMINUM
 HEATSINK CLIP: STAINLESS STEEL
 LIGHT PIPE MATERIAL: CLEAR POLYCARBONATE
- SURFACE FINISH:
 BODY CAGE: CLEANING
 EMI SPRING: CLEANING AND HOLE SEALING
 HEATSINK: BLACK ANODIZED
 HEATSINK CLIP: CLEANING
- MATE WITH QSFP MSA COMPATIBLE TRANSCEIVER.
- REFERENCE DOCUMENTS:
 PRODUCT SPECIFICATION: QSFP MSA
- THIS PRODUCT COMPLY TO ROHS DIRECTIVE 2011/65/EU.

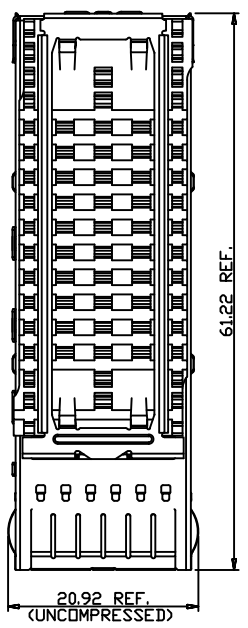
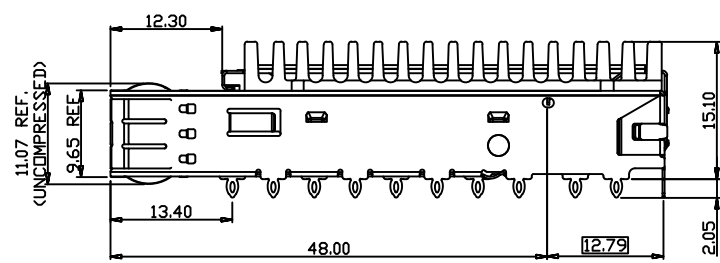
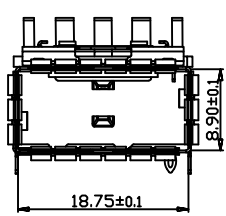

TITLE		LINK-PP INT'L TECHNOLOGY CO., LIMITED			
QSFP28 1X1 CAGE					
PART NO.		GENERAL TOLERANCE		UNIT:MM	SIZE: A4
LP11FC01051					
APPROVE	CHECK	DRAW	.X±0.20	.X±1'	SCALE: 1:1
James	Kevin	Kevin	.XX±0.15	.XX±5'	
			.XXX±0.10		
			SHEET:1/3	REV:A	

BEZEL AND BOARD POSITION DIMENSION
FOR SINGLE SIDE MOUNTING

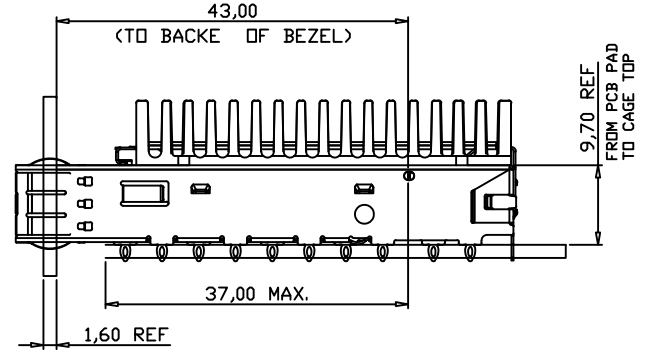
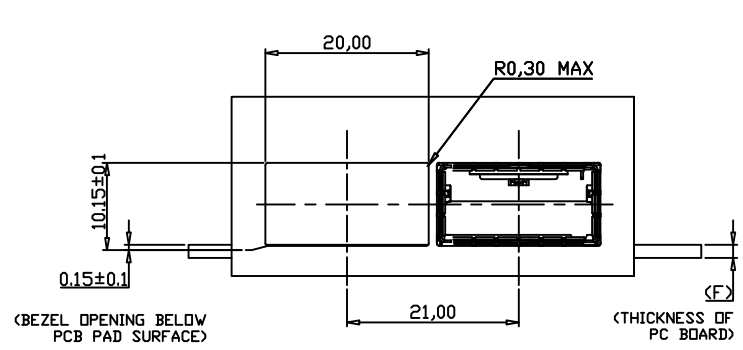

BEZEL AND BOARD POSITION DIMENSION
FOR BELLY TO BELLY MOUNTING

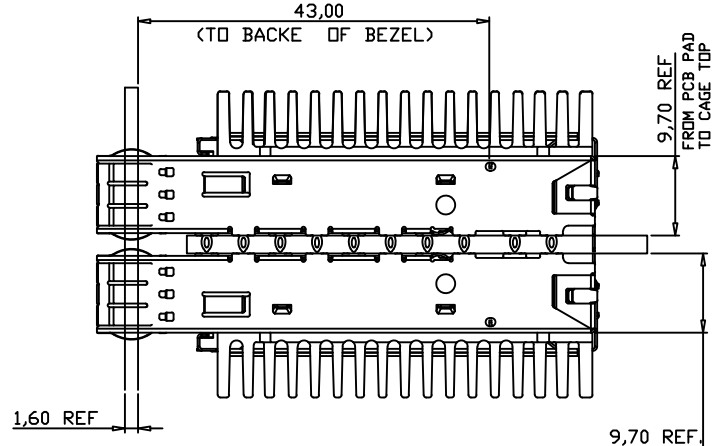
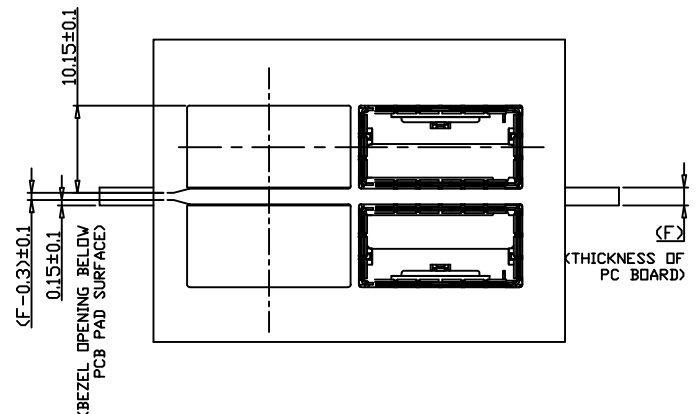

NOTES:

1. THE NORMAL THICKNESS OF CUSTOMER SUPPLIED PC BOARD.$\langle DIM. 'F' \rangle$
SINGLE SIDED PC BOARD THICKNESS: 1.60mm MIN.
BELLY TO BELLY PC BOARD THICKNESS: 3.0mm MIN.
2. GENERAL TOLERANCE: ± 0.05 .

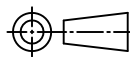

TITLE		QSFP28 1X1 CAGE		LINK-PP INT'L TECHNOLOGY CO., LIMITED				
PART NO.		LP11FC01051		GENERAL TOLERANCE			UNIT:MM	SIZE: A4
APPROVE	CHECK	DRAW	.X±0.20	.X±1'	SCALE: 1:1		SHEET:2/3	REV:A
James	Kevin	Kevin	.XX±0.15	.XX±5'				
			.XXX±0.10					

